

Reduce Downtime & Maintenance with DuraLev® Bearingless Pumps!



No Seals, No Bearings, No Problems!

DuraLev® 2000

4.1 bar (59 psi)
140 liters/min (37 gallons/min)

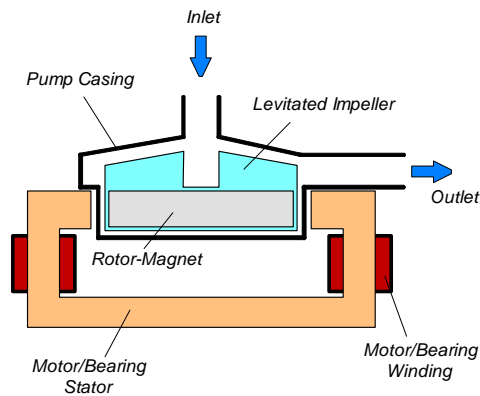

Figure 1: Schematic of the main elements of the bearingless centrifugal pump.

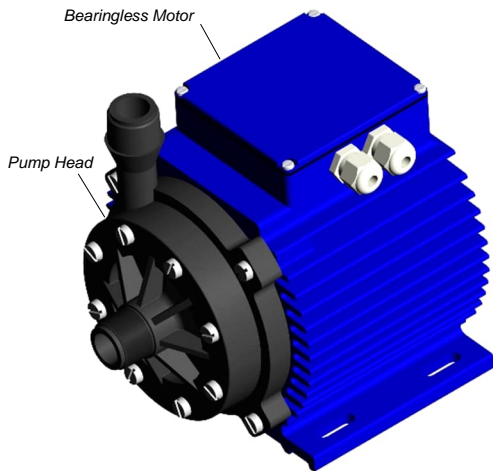

Figure 2: Bearingless pump motor and pump head LPP-2000.2 (PP)

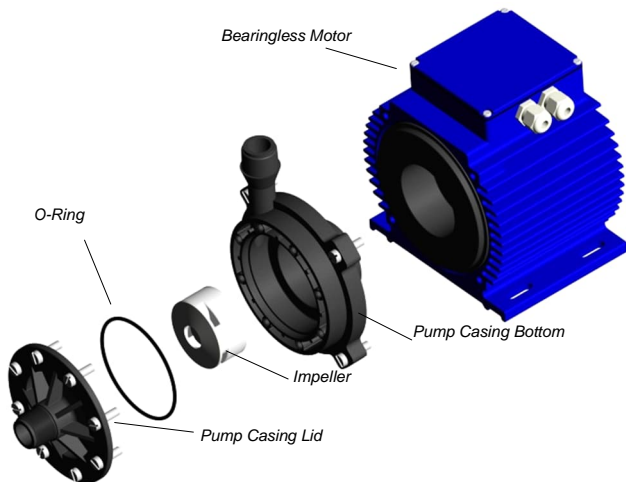

Figure 3: Disassembled pump head LPP-2000.2 (PP)

REVOLUTIONARY MAGNETICALLY LEVITATED CENTRIFUGAL PUMP

The *DuraLev®* pump system is a revolutionary centrifugal pump that has no bearings to wear out or seals to break down and fail. Based on the principles of magnetic levitation, the pump's impeller is suspended contact-free inside a sealed casing and is driven by the magnetic field of the motor (*Figure 1*). The impeller and casing are both fabricated from chemical-resistant fluorocarbon resins and together with the rotor magnet they make up the pump head. Fluid flow rate and pressure are precisely controlled by electronically regulating the rotor speed.

SYSTEM BENEFITS

- Increased equipment uptime and low maintenance costs by eliminating bearings and rotating seals.
- No clogging or freeze-up of bearings in gold, nickel and other plating applications.
- Improves and simplifies process control by accurately controlling both flow rate and rotor speed.
- Low shear pump design.
- Dry running capability
- Proven technology in medical and semiconductor industry (MTBF > 50 years)

APPLICATIONS

- Electronics manufacturing
- Galvanic plating
- Chemical production and handling
- Ideal for shear-sensitive liquids

STAND-ALONE SYSTEM CONFIGURATION

The stand-alone configuration of the *DuraLev® 2000* pump system consists of a controller with an integrated user panel allowing the operator to set the speed manually (see *Figure 7*). The speed is automatically stored in the internal EEPROM of the controller. As an option, the speed can also be set with an analog signal (see specification for *Position 3a* in *Table 2*).

EXTENDED SYSTEM CONFIGURATION

The extended version of the *DuraLev® 2000* pump system (*Figure 8*) consists of a controller with an extended PLC interface. The PLC interface allows the speed to be set via an external signal, facilitating precise closed-loop flow or pressure control when either a flow or pressure sensor is integrated into the system (see specification of *Position 3b* in *Table 2*). A computer can be connected via a USB interface to allow communication with *Levitronix® Service Software*. Hence parameterization, firmware updates and failure analysis are possible.

ATEX SYSTEM CONFIGURATION

An ATEX certified motor together with the pump head allows installation of motor and pump head within an ATEX Zone 2 area (see *Figure 9*). The certified motor (*Position 2b* in *Table 2*) comes with special connectors and according extension cables (*Position 4a* and *4b* in *Table 3*). An ATEX conform solution is necessary for the motor cables to leave the ATEX area. One option is an ATEX certified cable sealing system as listed in *Table 4* (*Pos. 8*).

The ATEX/IECEx motors have also a Japan and Korean Ex certification and marking.

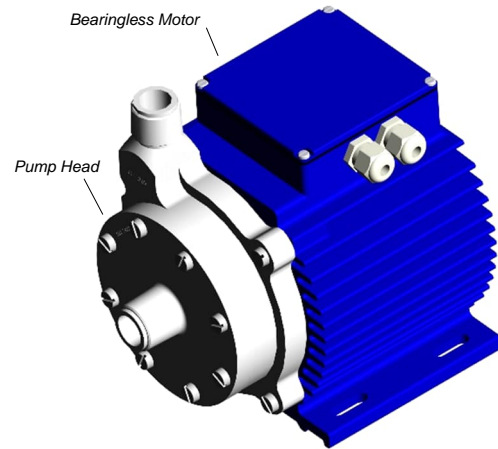

Figure 4: Cross-section of the bearingless pump motor and pump head LPP-2000.4 (PVDF)

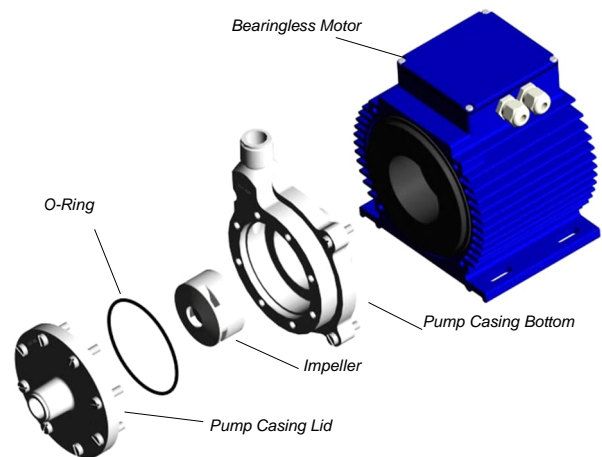

Figure 5: Disassembled pump head LPP-2000.4 (PVDF)

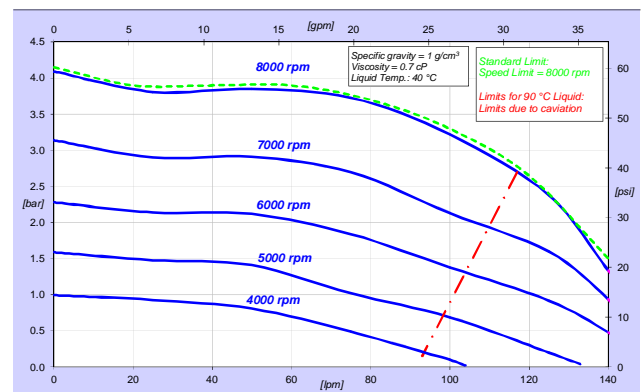

Figure 6: Pressure/flow curves (PVDF pump head LPP-2000.4)
 (Pressure for PP pump head LPP-2000.2 is ~3% lower)

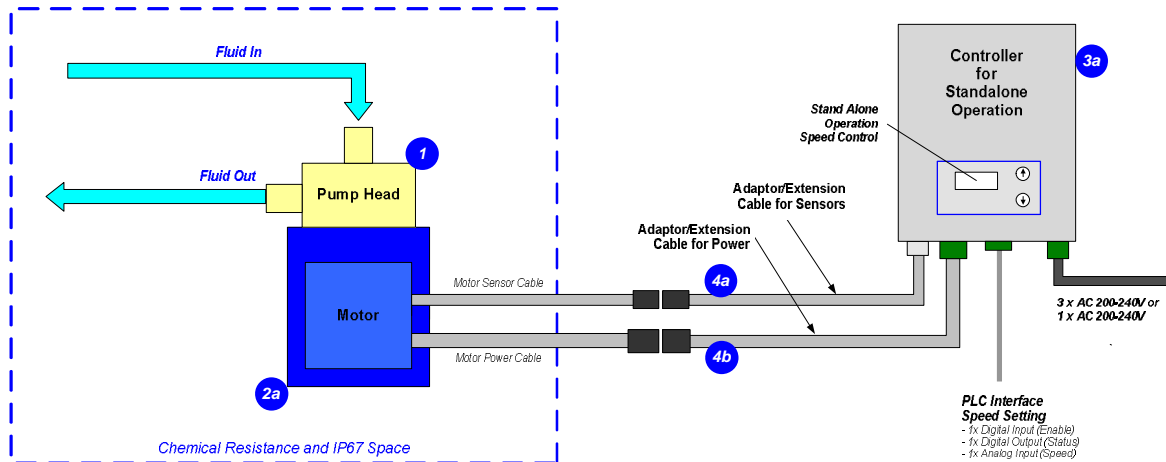

Figure 7: System configuration for standalone operation (Speed setting with integrated user panel)

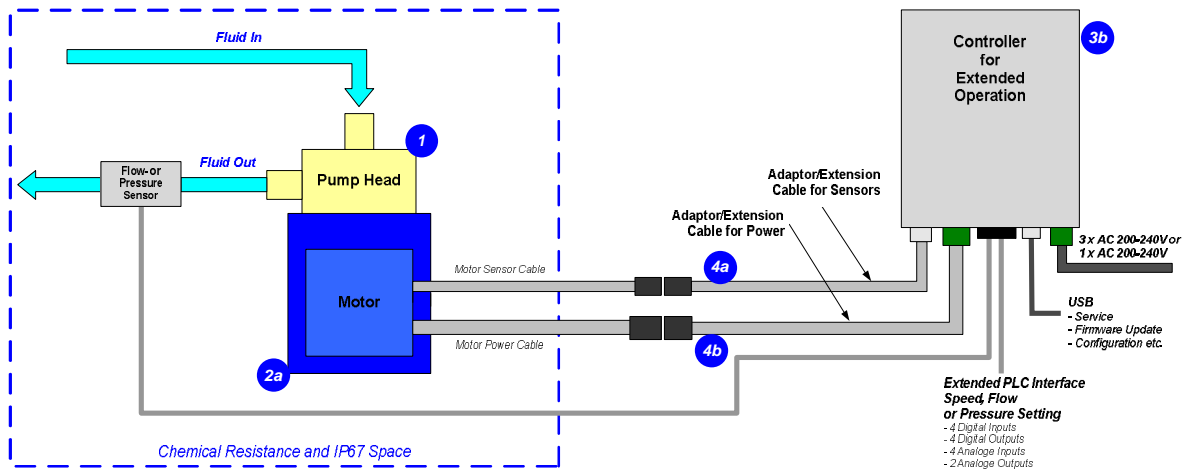

Figure 8: Extended operation (flow or pressure control) with extended controller

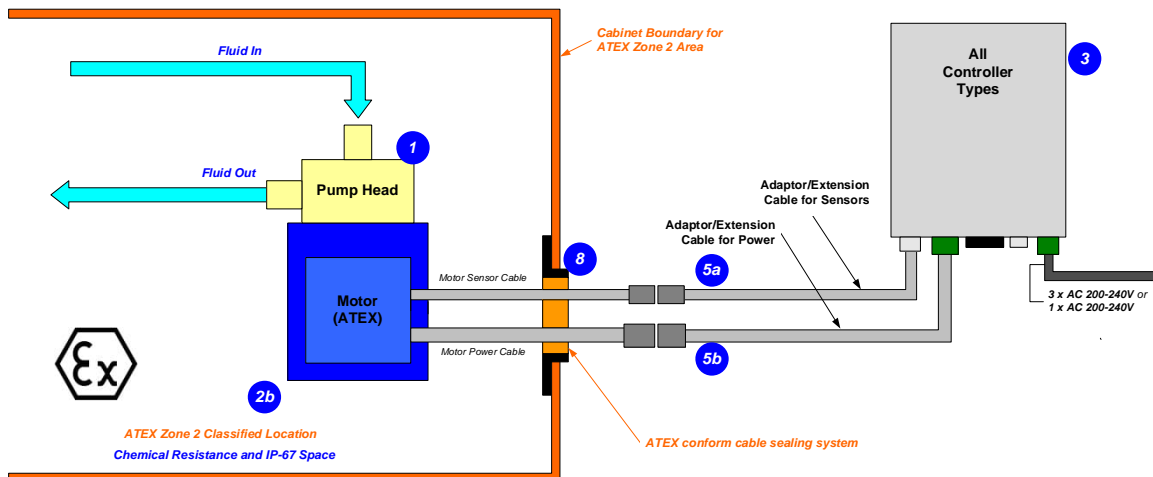

Figure 9: System Configuration for ATEX applications

DIMENSIONS OF MAIN COMPONENTS

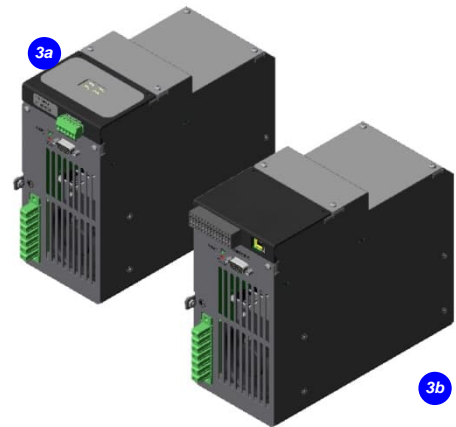
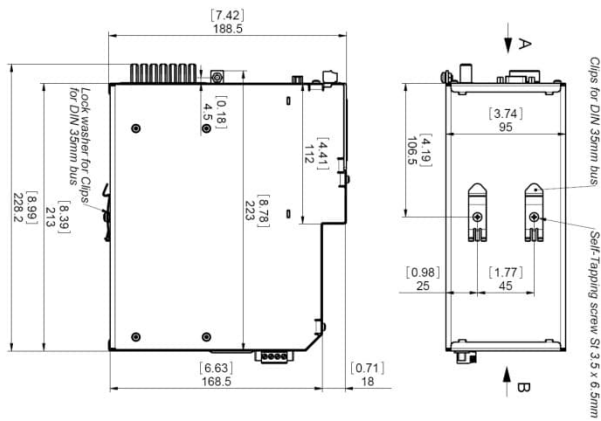

Figure 10: Dimensions of controllers LPC-2000.x
Note 1: Non tolerated dimensions are for reference only.

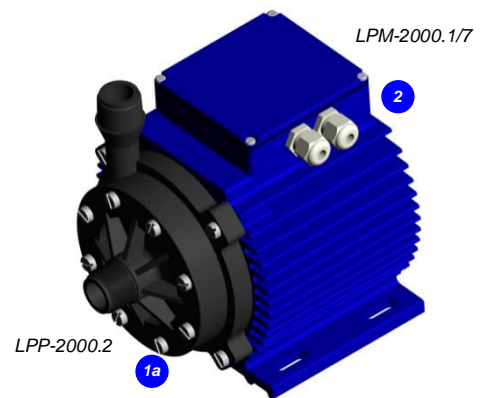
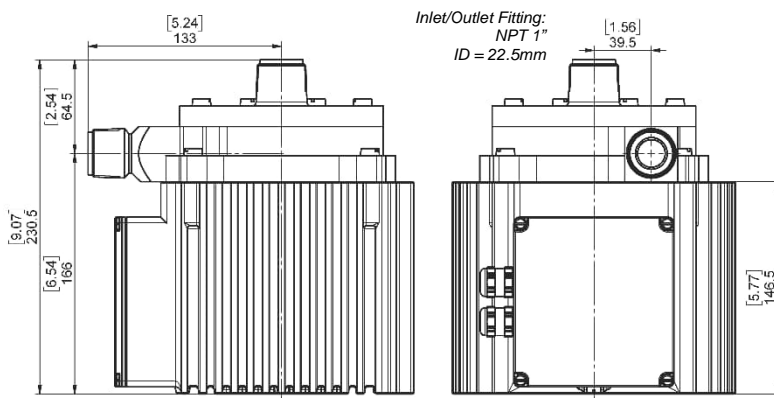

Figure 11: Dimensions of motor with pump head LPP-2000.2 (PP+GF30 Housing, PFA Impeller)
Note 1: Non tolerated dimensions are for reference only.

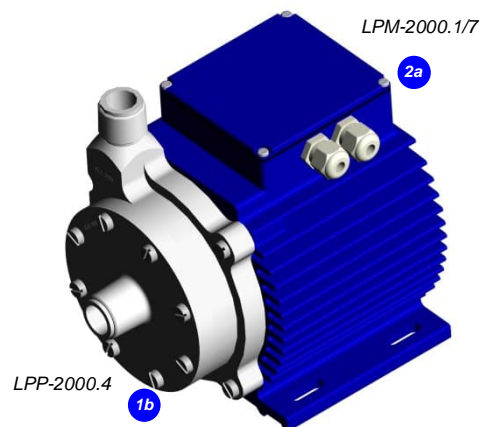
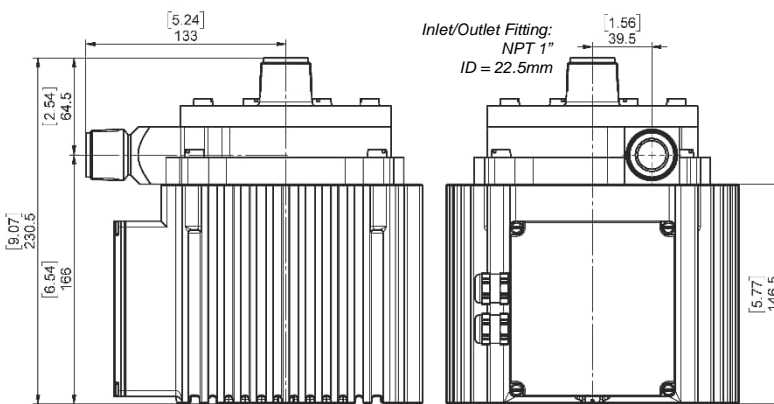

Figure 12: Dimensions of motor with pump head LPP-2000.4 (PVDF Housing, PFA Impeller)



DuraLev® 2000 Pumping without Bearings and Seals

System Name	Article #	Pump Head	Motor	Controller	Standard Firmware	Note
DuraLev® 2000.1 DuraLev® 2000.2 DuraLev® 2000.4 DuraLev® 2000.5	100-90491 100-90492 100-90494 100-90495	LPP-2000.4 (PVDF, NPT 1") LPP-2000.4 (PVDF, NPT 1") LPP-2000.2 (PP, NPT 1") LPP-2000.2 (PP, NPT 1")	LPM-2000.1	LPC-2000.1-01 (Stand-alone) LPC-2000.2-01 (PLC, USB) LPC-2000.1-01 (Stand-alone) LPC-2000.2-01 (PLC, USB)	E1.25 E1.48 E1.25 E1.48	Adaptor/Extension (0.5 - 10m) cables according to Table 3 (position 4a and 4b) have to be ordered as separate article with specified length. Certifications: CE, IECEx CB scheme, ETL (NRTL).
DuraLev® 2000.7 (ATEX) DuraLev® 2000.8 (ATEX) DuraLev® 2000.10 (ATEX) DuraLev® 2000.11 (ATEX)	100-90497 100-90498 100-90532 100-90533	LPP-2000.4 (PVDF, NPT 1") LPP-2000.4 (PVDF, NPT 1") LPP-2000.2 (PP, NPT 1") LPP-2000.2 (PP, NPT 1")	LPM-2000.7 (ATEX)	LPC-2000.1-01 (Stand-alone) LPC-2000.2-01 (PLC, USB) LPC-2000.1-01 (Stand-alone) LPC-2000.2-01 (PLC, USB)	E1.25 E1.48 E1.25 E1.48	Adaptor/Extension (0.5 - 10m) cables according to Table 3 (position 5a and 5b) have to be ordered as separate article with specified length. ATEX cable sealing system can be ordered according to Table 4 (Pos. 8). Certifications: CE, IECEx CB scheme, ETL (NRTL), ATEX/IECEx, Japan and Korean Ex certification.

Table 1: Standard system configurations

Pos.	Component	Article Name	Article #	Characteristics	Value / Feature
1a	Pump Head	LPP-2000.2 (PP, NPT 1")	100-90414	Impeller Pump Housing Sealing Ring Fittings	PFA PVDF or PP (+GF30) FPM (FKM) NPT 1"
1b		LPP-2000.4 (PVDF, NPT 1")	100-90416	Max. Flow Max. Diff.-Pressure Max. Viscosity / Max. Density Max. Liquid Temperature	140 liters/min / 37 gallons/min 4.1 bar / 59 psi (3% lower for PP pump head LPP-2000.2) 80 cP / 1.8 g/cm ³ 90°C / 194°F
2a	Motor	LPM-2000.1	100-10049	Housing Cable / Connectors	Epoxy (anticorrosive) coated Aluminum waterproofed (IP67 without connectors) 2x 3m cables with PVC jacket / 2x circular (AMP types)
2b	Motor (ATEX, IECEx)	LPM-2000.7	100-10059	ATEX/IECEx Marking ¹ Cable / Connectors	II 3G Ex ec h IIC T5 Gc II 3D Ex h tc IIIC T100°C Dc 2x 3m cables with PVC jacket / 2x circular (M23, IP67)
3a	Standalone Controller (User Panel)	LPC-2000.1-01 ("High Flow")	(Supply and Enable connector included) 100-30018	Voltage / Power Housing Rating Interfaces for Standalone Controller Firmware "High Flow"	1 and 3 x 200-240 V AC ±10% / 2kW @ 50/60Hz IP20 Panel to set speed (automatic storage on internal EEPROM) 1x analog input ("Speed") 4 - 20 mA 1x digital input ("Enable") 0 - 24 V (optocoupler) 1x digital output ("Status") 0 - 24 V (relais)
3b	Extended Controller (PLC and USB)	LPC-2000.2-01 ("High Flow")	(Supply and PLC connector included) 100-30021	Interfaces for Extended Controller Firmware "High Flow"	- up to 4 digital inputs 0 - 24V (optocoupler) - up to 4 digital outputs 0 - 24 V (relais) - up to 2 analog inputs 4 - 20mA - up to 2 analog inputs 0 - 10 V - up to 2 analog outputs 0 - 5 V USB interface (for service and system monitoring)

Table 2: Specification of standard components

Note 1: ATEX/IECEx motors are also certified and marked for Japan and Korean Ex.

Pos.	Component	Article Name		Article #		Characteristics	Value / Feature
		Sensor Cable	Power Cable	Sensor	Power		
4a	Extension Adaptor Cable for Sensor (a) and Power (b)	MCAS-600.1-05 (0.5m)	MCAP-2000.1-05	190-10122	190-10208	Jacket Material Connector Types Connector Material	PVC Circular AMP to D-SUB Plastics (PA)
4b		MCAS-600.1-30 (3m)	MCAP-2000.1-30	190-10123	190-10210		
		MCAS-600.1-50 (5m)	MCAP-2000.1-50	190-10124	190-10211		
		MCAS-600.1-70 (7m)	MCAP-2000.1-70	190-10101	190-10205		
		MCAS-600.1-100 (10m)	MCAP-2000.1-100	190-10125	190-10212		
5a	Extension Adaptor Cable for Sensor (a) and Power (b)	MCAS-600.3-05 (0.5m)	MCAP-2000.3-05	190-10158	190-10219	Jacket Material Connector Types Connector Material	PVC Circular M23 (IP-67) to D-SUB Metallic – Nickel coated
5b		MCAS-600.3-30 (3m)	MCAP-2000.3-30	190-10159	190-10221		
		MCAS-600.3-50 (5m)	MCAP-2000.3-50	190-10130	190-10222		
		MCAS-600.3-70 (7m)	MCAP-2000.3-70	190-10160	190-10223		
		MCAS-600.3-100 (10m)	MCAP-2000.3-100	190-10161	190-10224		

Table 3: Specification of adaptor/extension cables

Pos.	Component	Article Name	Article #	Characteristics	Value / Feature
6a	Air Cooling Module	ACM-4.2	190-10139	Material / Connection Port	PP (+ 40% Talkum) / NPT 1/4"
6b	Air Cooling Module	ACM-4.3	190-10243	Material	PP-EL-S with conductive additive for operation with ATEX motor
7a	Fan Cooling Module	FCM-2000.1	190-10390	Housing / Cable Spec. Supply Spec. / IP Rating	PP (+ 20% Talkum) white / PP jacket, 3m, circular sealed M12 connector (PP). 24 VDC, 33.5 W / IP-65 (fan is IP68 rated).
7b	Fan Cool. Module Cable	FCC-1.1-50 (5 m) FCC-1.1-100 (10 m)	190-10407 190-10408	Specification	PP cable jacket with circular M12 connector (PP) to open wires
8 (A-F)	ATEX Cable Sealing System	ACS-A.1 (Roxtec)	100-90292	Sleeve (A) and Gasket (B) Frame (C) 2x Cable Module (D)	Stainless Steel and EPDM Roxylon (EPDM rubber) Roxylon (EPDM rubber) Note: Lubricant (E) and measurement plates (F) are included.

Table 4: Specification of accessories

DuraLev® Bearingless Pump Technology
Your Solution for Trouble-Free Pumping



Figure 13: Basic components of pump system

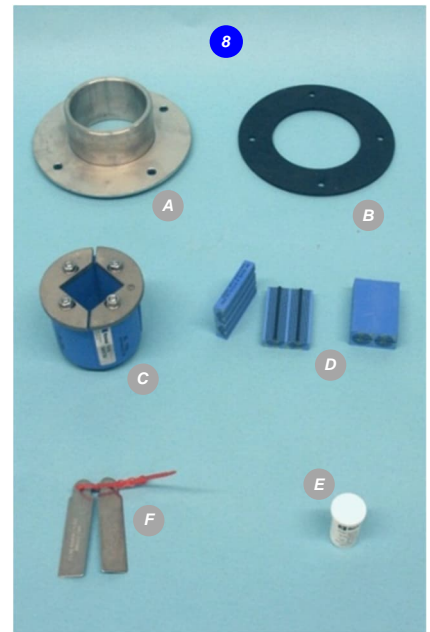

Figure 14: Accessories



LEVITRONIX® THE COMPANY

Levitronix® is the world-wide leader in magnetically levitated bearingless motor technology. Levitronix® was the first company to introduce bearingless motor technology to the Semiconductor, Medical and Life Science markets. The company is ISO 9001 certified. Production and quality control facilities are located in Switzerland. In addition, Levitronix® is committed to bring other highly innovative products like the LEVIFLOW® flowmeter series to the market.



Headquarter and European Contact

Levitronix GmbH
Bändliweg
CH-8048 Zurich
Switzerland

Phone: +41 44 974 4000
E-Mail: salesEurope@levitronix.com

US Contact

Levitronix Technologies Inc.
10 Speen Street, Suite 102
Framingham, Massachusetts 01701
USA

Phone: +1 508 861 3800
E-Mail: salesUS@levitronix.com

Japan Contact

Levitronix Japan K.K.
Wing Eight 5floor, 4-16-4
Asakusabashi, Taito-ku
Tokyo, 111-0053 Japan

Phone: +81 3 5823 4193
E-Mail: salesJapan@levitronix.com

Taiwan Contact

Levitronix Taiwan
5F, No. 251, Dong Sec. 1, Guang-
ming 6th Rd., Chu Pei City,
Hsin-Chu 302, Taiwan, R.O.C.

Phone: +886 3 657 6209
E-Mail: salesAsia@levitronix.com

This document and its content is the property of Levitronix® and shall not be reproduced, distributed, disclosed or used for manufacturing or sale of Levitronix® products without the expressed written consent of Levitronix®.