

Ultrapure Fluid Handling Integrated Flow Controller Series



BPS-iF30

Pump Pressure / Flow:

Standard: 1.5 bar / 7.4 l/min High Pressure: 2.8 bar / 3.8 l/min

Flow Control Range: 4 l/min

High Precision. No Bearings. No Contamination!

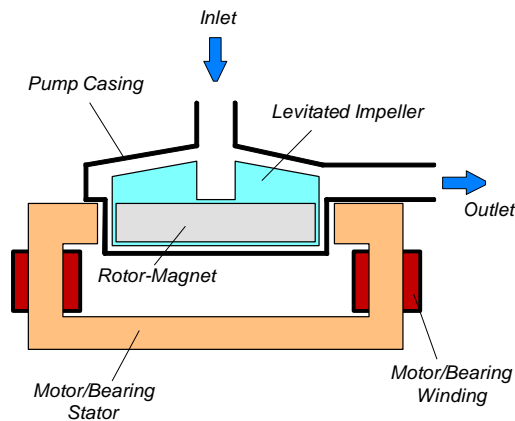

Figure 1: Schematic of the main elements of the MagLev centrifugal pump

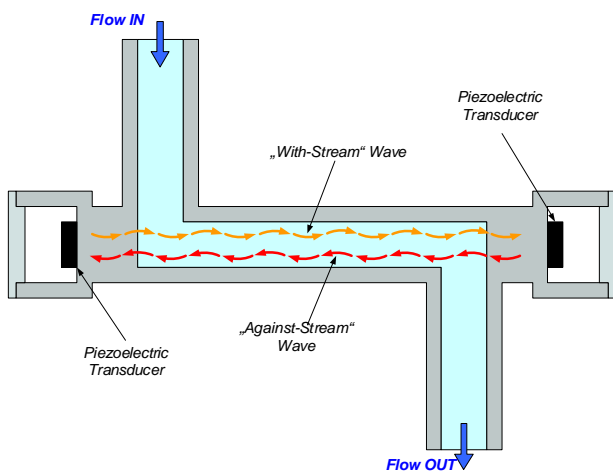

Figure 2: Operating principle ultrasonic flowmeter sensor with Z-shape (same principle with U-shape)

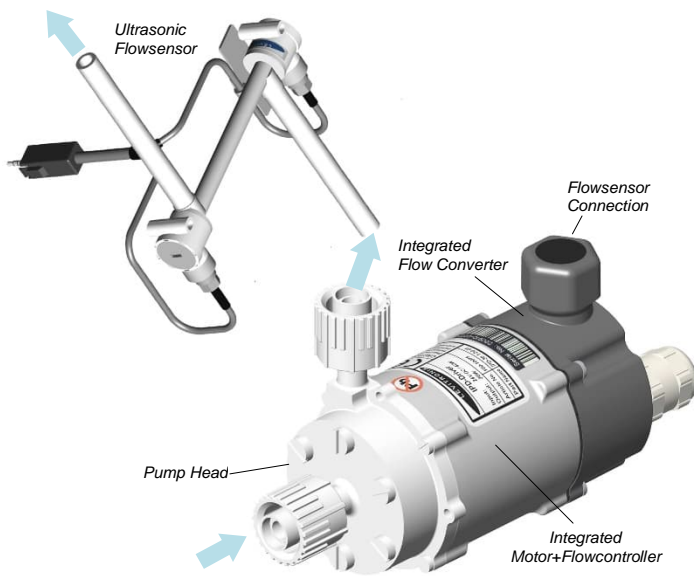

Figure 3: Integrated MagLev flow control system with ultrasonic flow sensor

INTRODUCTION

With the *BPS-iF30* flow control system *Levitronix*[®] combines its unique magnetic levitation pump technology with its ultrasonic flow measurement technology. The result is a highly integrated precise flow controller with an integrated pressure source.

The centrifugal pump, as a pressure source, has no bearings to wear out or seals to break down and fail. The pump impeller is suspended, contact-free, inside a casing and is driven by the magnetic field of the motor (*Figure 1*).

The flow is measured with the proven *LEVIFLOW*[®] ultrasonic sensor technology not invading into the fluid path (*Figure 2*).

The pump head and flow sensor are fabricated from chemical-resistant high purity fluorocarbon resins. The pump controller, motor and flow converter are integrated into the driver housing (see *Figure 3*). This reduces cabling and setup effort significantly. Fluid flow rate is precisely controlled by electronically regulating the impeller speed without pulsation.

SYSTEM BENEFITS

- High precision, dynamics and turndown ratio.
- No dependency on external pressure source.
- Extremely low particle generation due to the absence of mechanically contacting parts.
- Increased equipment uptime with lower maintenance costs by eliminating valves, bearings, rotating seals and costly rebuilds.
- Very low integration costs as no external controller is needed for flow control.
- Reduced risk of contamination due to the self-contained design with magnetic bearings and ultrasonic technology.
- Very gentle to sensitive fluids due to low-shear design.
- No narrow gaps and fissures where particles or microorganisms could be entrapped.
- Smooth, continuous flow without pressure pulsation.
- Proven pump and ultrasonic flow measurement technology.

APPLICATIONS

- Semiconductor wet processing (Cleaning, CMP etc.).
- Flip chip and advanced packaging.
- Solar cell production.
- Flat panel display manufacturing.
- Hard-disk fabrication.
- Printer ink handling.
- Pharmaceutical production.
- Plating.
- Circulation in flow batteries.

REVOLUTIONARY FLOW CONTROL SYSTEM

FLOW CONTROL CONCEPT

Flow control, pressure generation and flow measurement are done with one unit (see *Figure 5*). This allows realization of sophisticated flow control algorithms and optimizations to various situations. There is a linear relationship between flow and speed. The speed is precisely controlled with a high resolution over a wide pump speed range. This allows a flow control with high resolution and high turndown ratio compared to non-linear flow control with valve type flow control concepts. The highly dynamic speed controller allows fast flow step responses. As the speed is monitored and the pressure cannot increase uncontrolled at a given speed, there is no need to protect the hydraulic circuit against over-pressure situations as for example for roller pumps in tube clogging situations. The versatility the *Levitronix*® flow control systems goes far beyond the capabilities of simple flow controllers. In addition to the flow control function, the *Levitronix*® control firmware comes with several condition monitoring features to monitor the integrity of the fluid circuit. *Levitronix*® flow control systems can generate alarms for preventive filter exchange, no-flow conditions or line clogging. Dynamic Condition Trending (DCT) enables failure prediction and scheduling of preventive maintenance.

SYSTEM CONFIGURATION – “STAND-ALONE”

Figure 7 and *Figure 11* illustrate a “Plug and Play” stand-alone system with integrated user panel to set the flow manually. The driver also contains a PLC interface for remote flow control by analog and digital signals. Various accessories are available like a desktop power supply with relevant power cable and signal cables to connect to the PLC.

SYSTEM CONFIGURATION – “EASYCONNECT”

The “EasyConnect” models (see *Figure 9* and *Figure 13*) with according cable accessories are designed to realize various interface configurations with minimal setup effort. Two Fieldbus connectors allow to chain multiple flow controllers. Therefore, blending configurations as shown in *Figure 10* can be realized. The PLC interface allows not only remote control by analog/digital signals but also connections of external sensors hence enabling for example a precise flow or pressure control. The Fieldbus interface allows remote control over a PC, a User Panel or other devices with Modbus protocol.

SYSTEM CONFIGURATION – “OEM”

The “OEM” models are designed for a compact integration with one integrated hybrid cable containing all available interface signals (see *Figure 8* and *Figure 15*). Basically, all configurations of the “EasyConnect” models are possible allowing the users with integration capabilities to adapt the cable to their needs.

ATEX / IECEx SYSTEM CONFIGURATION

An ATEX / IECEx certified driver (OEM model only) together with the pump head allows installation within an ATEX Zone 2 area (see *Figure 8*). An Ex conform solution is needed for the motor cables to leave the ATEX area. One option is an ATEX certified cable sealing system as listed in *Table 5* (see *Pos. 14*).

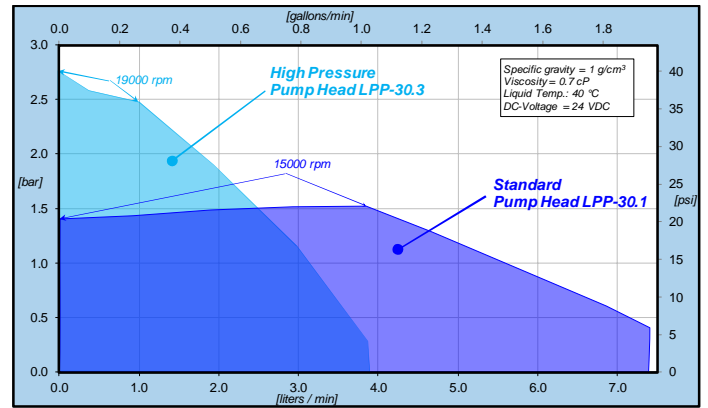

Figure 4: Pressure/flow curves for aqueous liquids (similar to water)

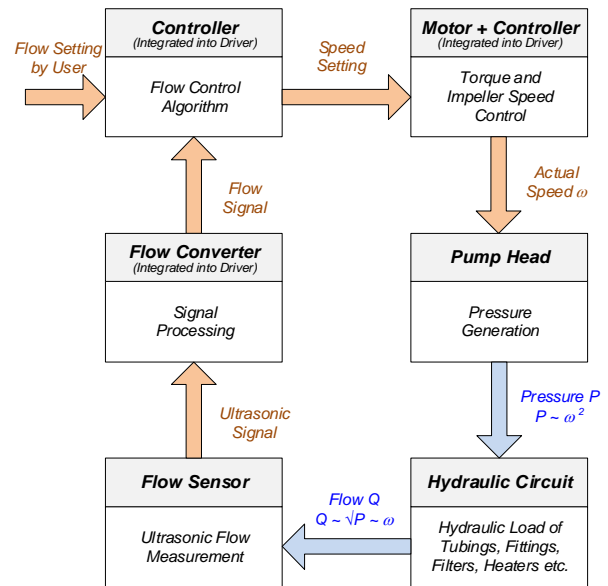

Figure 5: Simplified block schematics of flow control with BPS-IF30



Figure 6: Flow control system models

SYSTEM CONFIGURATIONS

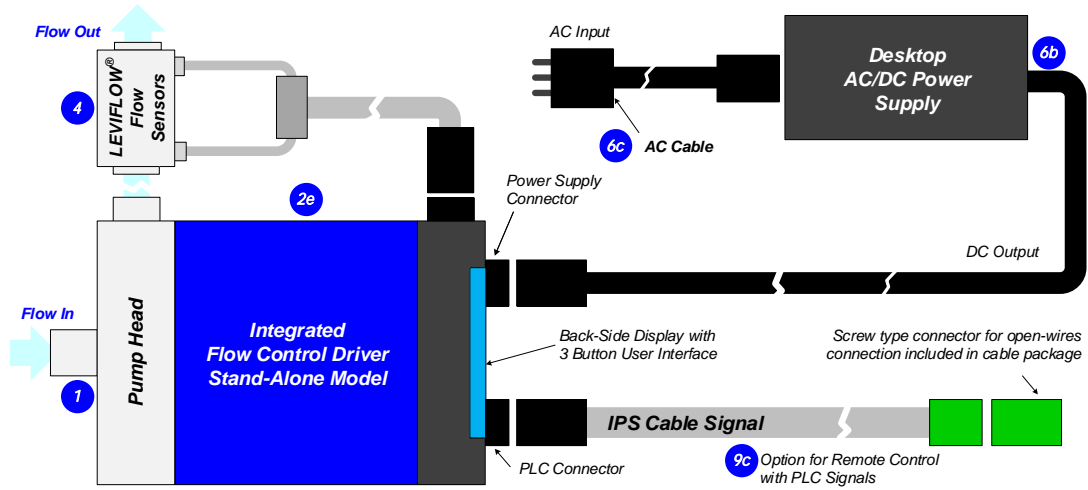

Figure 7: Standard "Stand-Alone" system configuration with main accessories
 (See section "Order Information" for details to numbered components and other options)

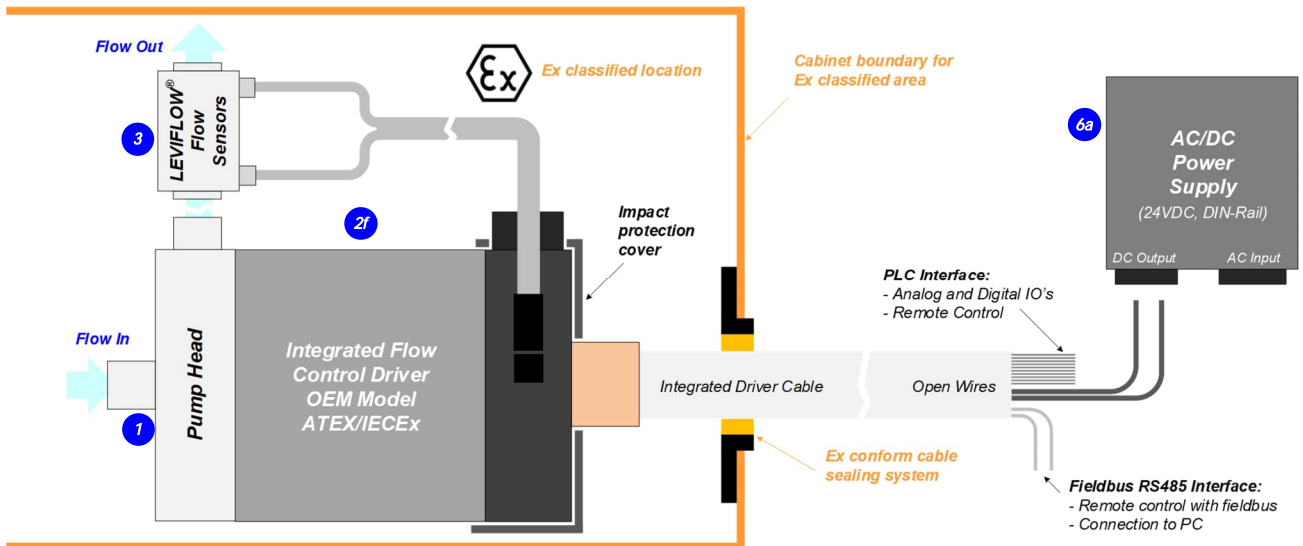
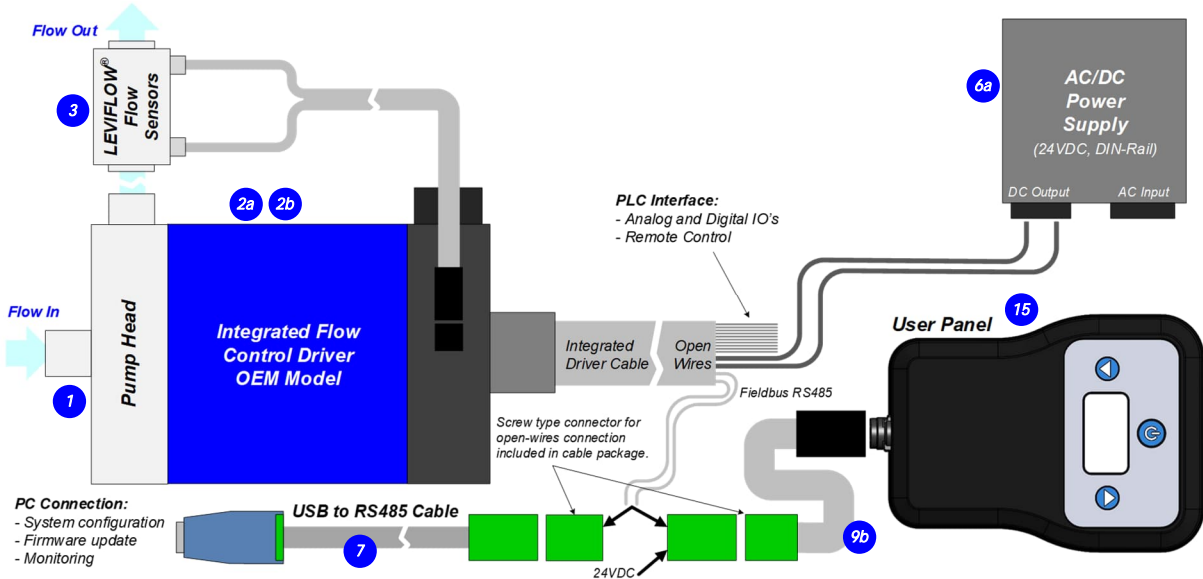

Figure 8: Standard "OEM" system configuration and ATEX/IECEx OEM system configuration
 (See section "Order Information" for details to numbered components and other options)

SYSTEM CONFIGURATIONS

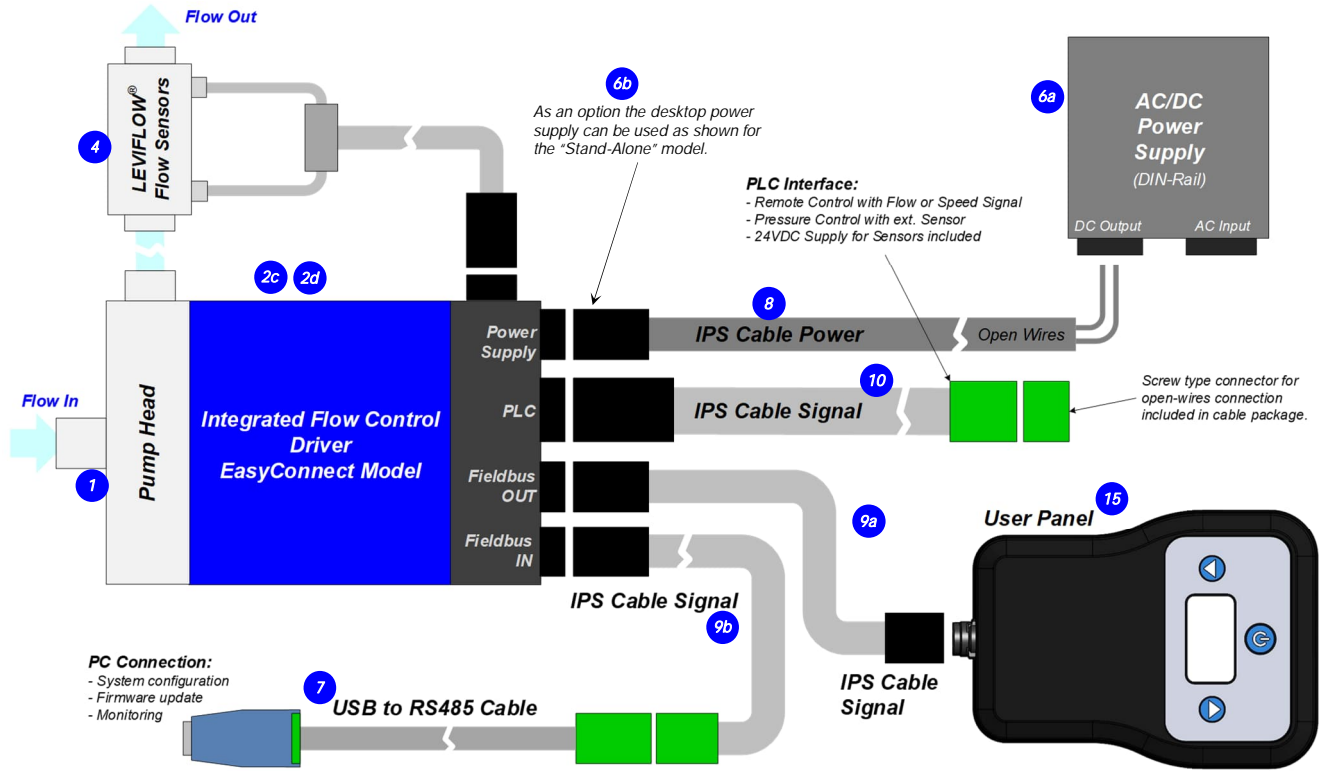

Figure 9: Standard "EasyConnect" system configuration with main accessories
(See section "Order Information" for details to numbered components and other options.)

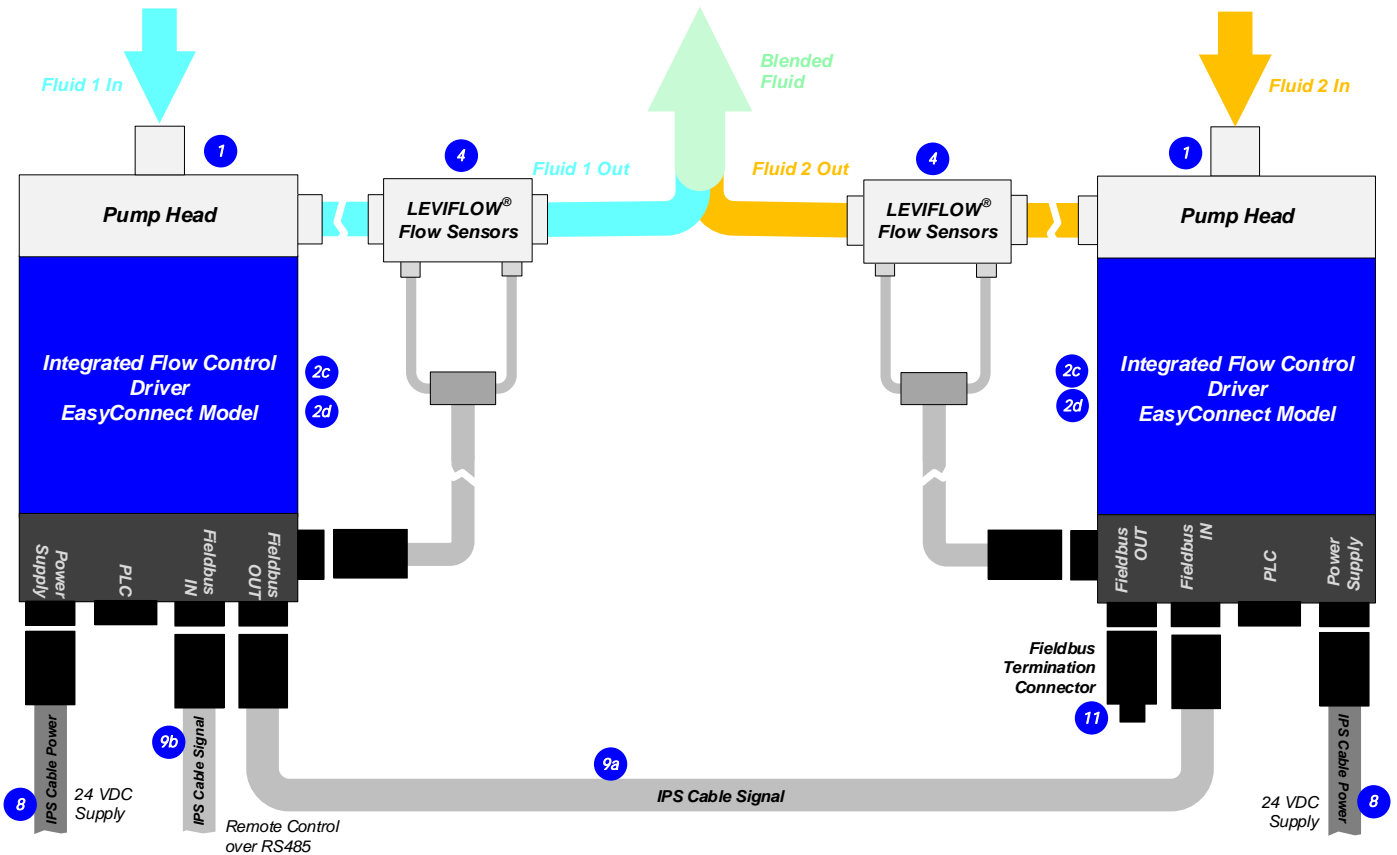

Figure 10: Multi-system configuration with "EasyConnect" models for blending applications
(See section "Order Information" for details to numbered components and other options.)

MODEL DESCRIPTION – STAND-ALONE



Interface	PIN Name	Description	Standard Designation	Hardware Specification
Power Supply	P+	+ 24 VDC	Supply	Voltage: 24 VDC Power: 35 W
	P-	Power Input Ground / Earth		
	NC	Not connected.		
PLC 6	Ain	Analog Input (Current Input)	Reference Flow	Analog current input: 4 – 20 mA (450 Ohm shunt input, no galvanic isolation)
	Ain_GND	Analog In. GND	--	Reference for Ain
	Dout	Digital Output 1	Status	Open drain, max. 24V, 100mA Reference ground is GND
	GND	Analog Ground	--	Reference for Dout
	Din1	Digital Input 1	Enable (Reset)	Galvanic separation with optocoupler 2.2 kΩ input resistance, 5-24V for active input
	Din_COM	Com. Digi. Input	--	Reference for digital input.
Flow Sensor	6 Pins	Flow Sensor	--	Compatible to LEVIFLOW® flow sensors LFS-04L-F1.
Display and Buttons	--	Display	Flow and Status Display	--
	--	Up/Down	Setting Flow	--
	--	On/Off	Enable/Disable	--

Figure 11: Interface specifications of standard "Stand-Alone" model

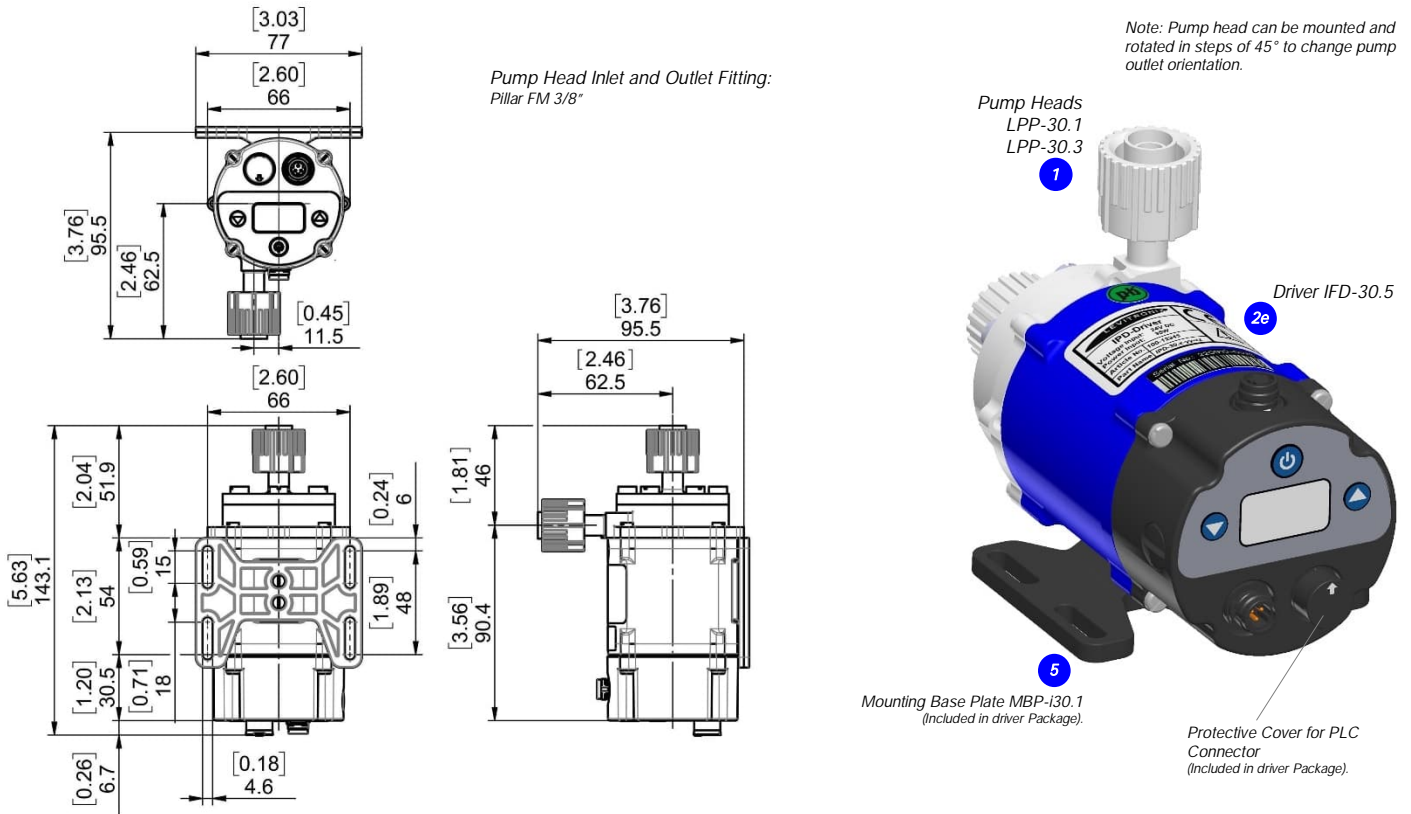
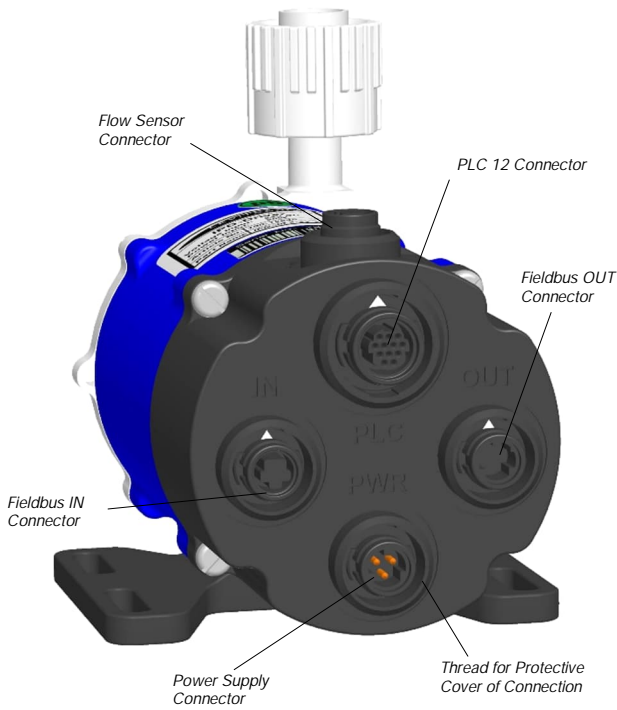

Figure 12: Basic dimensions and description of standard "Stand-Alone" model
Note 1: Dimensions without tolerance are for reference only.

MODEL DESCRIPTION – EASYCONNECT



Connector	PIN Name	Description	Standard Designation	Hardware Specification
Power Supply	P+	+ 24 VDC	Supply	Voltage: 24 VDC Power: 35 W
	P-	Ground / Earth		
	NC	Not connected.		
PLC 12	Dout1	Digital Output 1	Status Pump	Open drain, max. 24V, 100mA
	Dout2	Digital Output 2	Status Flow Sen	Reference ground is GND
	Din1	Digital Input 1	Enable (Reset)	Galvanic separation with optocoupler
	Din2	Digital Input 2	Zero Adjust	2.2 kΩ input resistance, 5-24V for active input
	Din_COM	Com. Digi. Input	--	Reference for digital input.
	Ain1	Analog Input 1 (Current Input)	Reference Value (Set Flow)	Analog current input: 4 – 20 mA (450 Ohm shunt input, no galvanic isolation)
	Ain2	Analog Input 2 (Voltage Input)	Free configurable	Analog voltage input: 0 – 10V (7.9 kOhm, no galvanic isolation)
	Ain_GND	Analog In. GND	--	Reference for Ain1 and Ain2
	Aout1	Analog Output (Voltage Output)	Actual Flow	0 – 10V (no galvanic isolation) GND is reference
	GND	Analog Ground	--	Reference for Aout1, Dout1, Dout2 and Pout
	Pout	Output +24VDC	Supply Output	For supply of external devices (e.g. sensors). (Current 200mA together with Pout or Fieldbus OUT)
	NC	Not connected.	--	--
GND	Ground	--	Reference for Pout.	
Fieldbus OUT	Pout	Output +24VDC	Supply Output	For supply of external devices (user panels) (Current 200mA together with Pout of PLC 12)
	RS485+	RS485 +	Fieldbus	Modbus RTU protocol
	RS485-	RS485 -		
	Internal	Internal Bus	Do not connect	Internal bus needed to connect pumps for serial pumping.
Fieldbus IN	Internal	Internal Bus	Do not connect	Internal bus needed to connect pumps for serial pumping.
	GND	Ground	--	Connected to PLC12 GND and reference for supply
	NC	Not connected.	--	--
	RS485+	RS485 +	Fieldbus	Modbus RTU protocol
RS485-	RS485 -			
Flow Sensor	Internal	Internal Bus	Do not connect	Internal bus needed to connect pumps for serial pumping.
	Internal	Internal Bus	Do not connect	Internal bus needed to connect pumps for serial pumping.
	6 Pins	Flow Sensor	--	Compatible to LEVIFLOW® flow sensors LFS-04L-F1.

Figure 13: Interface specifications of standard "EasyConnect" model

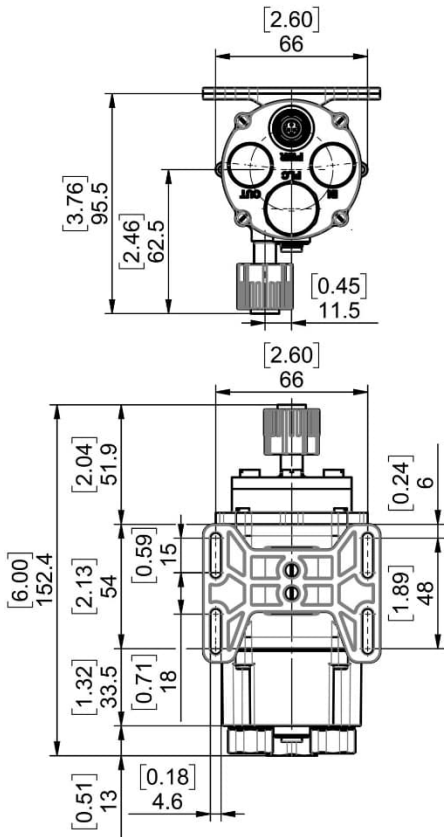

Note: Pump head can be mounted and rotated in steps of 45° to change pump outlet orientation.

Pump Head Inlet and Outlet Fitting:
Pillar FM 3/8"



Figure 14: Basic dimensions and description of standard "EasyConnect" model
Note 1: Dimensions without tolerance are for reference only.

FLOW SENSOR SPECIFICATIONS

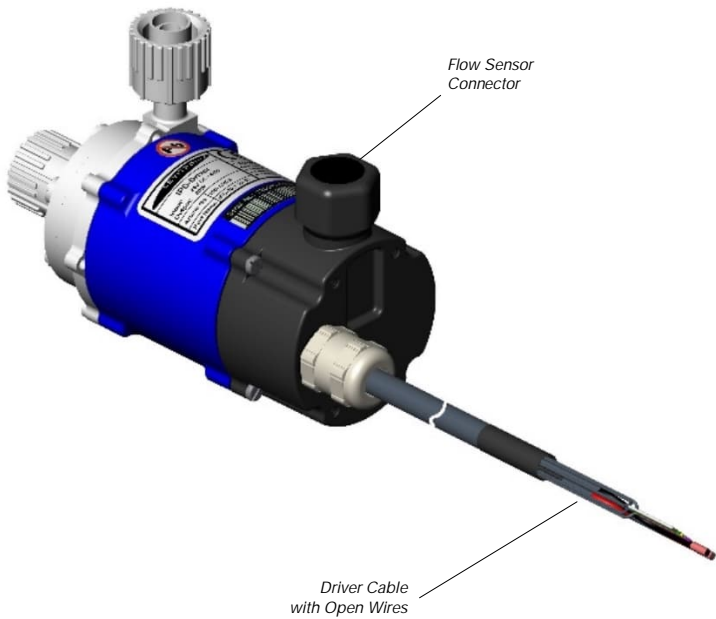

Wire Name	Description	Standard Designation	Hardware Specification
P+	+ 24 VDC	Supply	Voltage: 24 VDC P- to be connected to earth
P-	Power Input Ground / Earth		
Ain1	Analog Input 1 (Current Input)	Reference Value (Set Flow)	Analog current input: 4 – 20 mA (450 Ohm shunt input, no galvanic isolation)
Ain2	Analog Input 2 (Voltage Input)	Free Configurable	Analog voltage input: 0 – 10V (7.9 kOhm, no galvanic isolation)
Ain_GND	Analog Input, Ground	--	Reference for Ain1 and Ain2
Din1	Digital Input 1	Enable (Reset)	Galvanic separation with optocoupler
Din2	Digital Input 2	Zero Adjust	2.2 kΩ input resistance, 5-24V for active input
Din_COM	Common Digital Input	--	--
Aout1	Analog Output	Actual Flow	0 – 10V (no galvanic isolation) GND is reference
Dout1	Digital Output 1	Status Pump	Open drain, max. 24V, 100mA
Dout2	Digital Output 2	Status Flow Sens.	Reference ground is AGND
GND	Analog Ground	--	Reference for Aout1, Dout1 and Dout2
RS485+	RS485 +	Fieldbus	Modbus RTU protocol
RS485-	RS485 -		
Internal	Internal Bus	Do not connect	--
Internal	Internal Bus	Do not connect	--
Shield	Shielding	Shielding	To be connected to earth (see wire P-)

Figure 15: Interface specifications of standard "OEM" and for "OEM" ATEX / IECEx models

Note 1: Power supply wire cross-section is 1.5 mm² and for signal wires 0.14 mm²

Note 2: For more detailed description of interfaces consult user manual

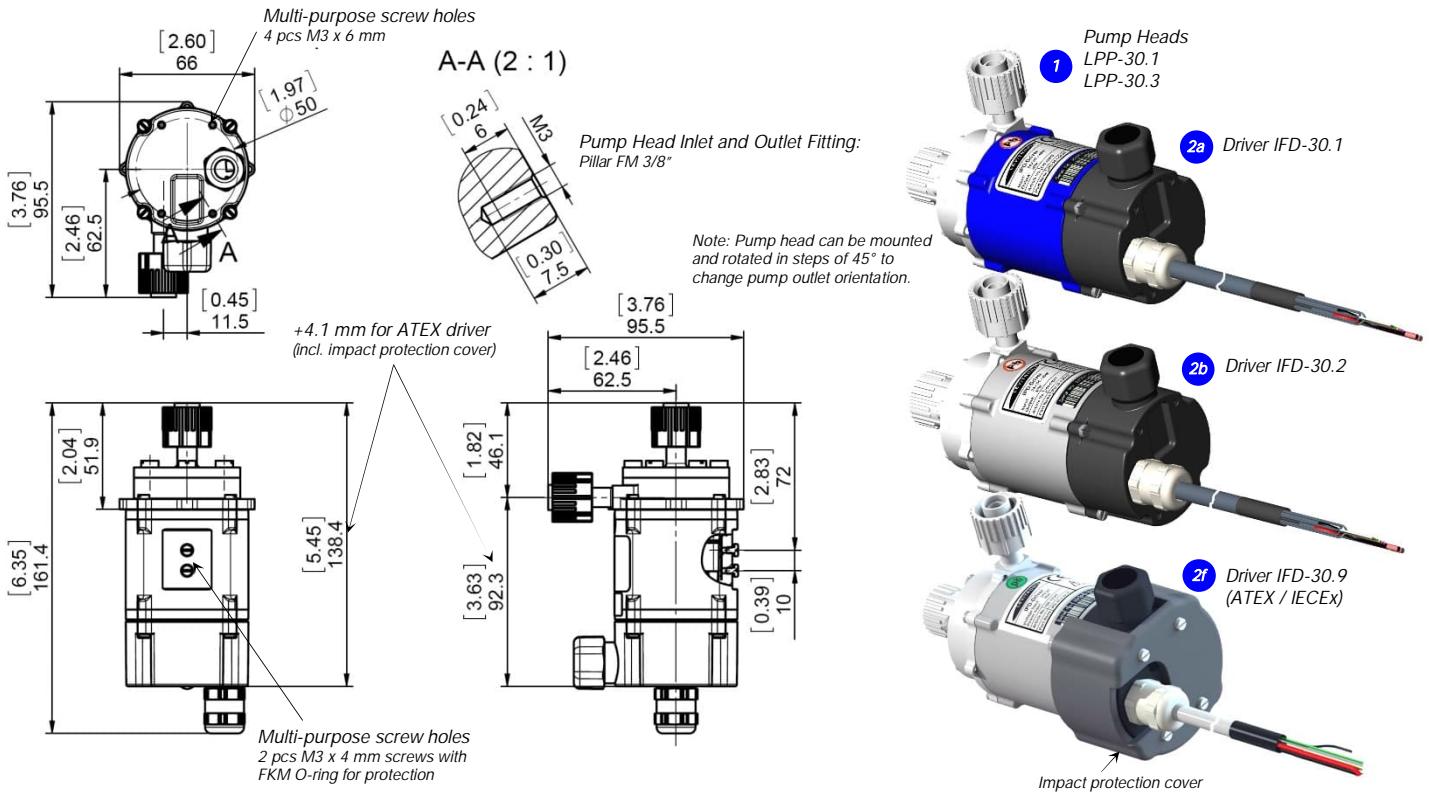

Figure 16: Basic dimensions and description of standard "OEM" model

Note 1: Dimensions without tolerance are for reference only.

ORDER INFORMATION

System Name	Article #	Flow Sensor	Flow Control Driver	Pump Head	Note
BPS-IF30.1-04LZSC1 / -04LUSC1	100-91027 / 100-91028	LFS-04L-Z-F1-SC1 / LFS-04L-U-F1-SC1	IFD-30.1-50-01 (Epoxy)	LPP-30.1	
BPS-IF30.2-04LZSC1 / -04LUSC1	100-91029 / 100-91030	LFS-04L-Z-F1-SC1 / LFS-04L-U-F1-SC1	IFD-30.2-50-01 (ETFE)	LPP-30.1	OEM models ¹
BPS-IF30.3-04LZSC1 / -04LUSC1	100-91279 / 100-91280	LFS-04L-Z-F1-SC1 / LFS-04L-U-F1-SC1	IFD-30.1-50-03 (Epoxy)	LPP-30.3	
BPS-IF30.4-04LZSC1 / -04LUSC1	100-91281 / 100-91282	LFS-04L-Z-F1-SC1 / LFS-04L-U-F1-SC1	IFD-30.2-50-03 (ETFE)	LPP-30.3	
BPS-IF30.5-04LZSC1 / -04LUSC1	100-91378 / 100-91379	LFS-04L-Z-F1-SC1 / LFS-04L-U-F1-SC1	IFD-30.9-50-01 (ETFE)	LPP-30.1	OEM models ATEX/IECEx ¹
BPS-IF30.6-04LZSC1 / -04LUSC1	100-91380 / 100-91381	LFS-04L-Z-F1-SC1 / LFS-04L-U-F1-SC1	IFD-30.9-50-03 (ETFE)	LPP-30.3	
BPS-IF30.7-04LZPCSC1 / -04LUPCSC1	100-91382 / 100-91383	LFS-04L-Z-PC-F1-SC1 / LFS-04L-U-PC-F1-SC1	IFD-30.4-01 (Epoxy)	LPP-30.1	
BPS-IF30.8-04LZPCSC1 / -04LUPCSC1	100-91384 / 100-91385	LFS-04L-Z-PC-F1-SC1 / LFS-04L-U-PC-F1-SC1	IFD-30.7-01 (ETFE)	LPP-30.1	EasyConnect models ²
BPS-IF30.9-04LZPCSC1 / -04LUPCSC1	100-91386 / 100-91387	LFS-04L-Z-PC-F1-SC1 / LFS-04L-U-PC-F1-SC1	IFD-30.4-03 (Epoxy)	LPP-30.3	
BPS-IF30.10-04LZPCSC1 / -04LUPCSC1	100-91388 / 100-91389	LFS-04L-Z-PC-F1-SC1 / LFS-04L-U-PC-F1-SC1	IFD-30.7-03 (ETFE)	LPP-30.3	
BPS-IF30.11-04LZPCSC1 / -04LUPCSC1	100-91390 / 100-91391	LFS-04L-Z-PC-F1-SC1 / LFS-04L-U-PC-F1-SC1	IFD-30.5-01 (Epoxy)	LPP-30.1	Stand-Alone model ²
BPS-IF30.12-04LZPCSC1 / -04LUPCSC1	100-91392 / 100-91393	LFS-04L-Z-PC-F1-SC1 / LFS-04L-U-PC-F1-SC1	IFD-30.5-03 (Epoxy)	LPP-30.3	

Table 2: Standard flow control system configurations

Note 1: Flow control driver comes delivered with flow sensor calibration parameters stored in driver if ordered as a set. Note 2: Calibration parameters stored on flow sensor and transferred automatically to driver.

Pos.	Component	Article Name	Article #	Characteristics	Value / Feature
1a	Pump Head	LPP-30.1 (Standard)	100-90828	Impeller / Pump Housing Sealing O-Ring / In-/Outlet Fittings	PTFE / PTFE FFPM (FFKM) perfluoroelastomer / 3/8" Pillar Super 300 FM (female)
1b		LPP-30.3 (High Press)	100-91213	Max. Flow / Max. Diff.-Pressure Max. Viscosity / Max. Liquid Temp.	a) 7.4 lpm (2 gpm) / 1.5 bar (22 psi) b) 3.8 lpm (1qpm) / 2.8 bar (40 psi) 10 cP / 90 °C (194 °F) Note: ATEX driver IFD-30.9 has max. 70 °C.
2a	Integrated Flow Control Driver ("OEM Models")	IFD-30.1-50-01 (Standard)	100-10094	Voltage, Power	24 VDC ±10%, 35 W
2b		IFD-30.1-50-03 (High Press.)	100-10142	Housing Cable	Epoxy (a) or ETFE (b) coated Aluminum, PP for bottom lid, IP65 ¹ PVC (a) or FEP (b) jacket, open wires, cable length 5 m
		IFD-30.2-50-01 (Standard)	100-10099	Interfaces	PLC and RS485 with Modbus RTU protocol (see Figure 15 for details)
2c	IFD-30.2-50-03 (High Press.)	100-10143	Standard Firmware	For Standard pump head: K1.48 For High Pressure pump head: K3.48	
	Integrated Flow Control Driver ("EasyConnect" Models) (MBP-130.1 included)	IFD-30.4-01 (Standard)	100-10172	Housing	Epoxy (c) or ETFE (d) coated Aluminum, PP for bottom lid, IP65
2d	IFD-30.4-03 (High Press.)	100-10173	Interfaces	2x Fieldbus RS485 with Modbus RTU protocol	
	IFD-30.7-01 (Standard)	100-10176	Standard Firmware	PLC and power supply	
2e	Integrated Flow Control Driver ("Stand-Alone" Model) (MBP-130.1 included)	IFD-30.7-03 (High Press.)	100-10177	Standard Firmware	For Standard pump head: K1.48 For High Pressure pump head: K3.48
	IFD-30.5-01 (Standard)	100-10174	Housing	Epoxy coated Aluminum, PP for bottom lid, IP65	
2f	Integrated Flow Control Driver (ATEX/IECEx ("OEM Models" only))	IFD-30.5-03 (High Pressure)	100-10175	Interfaces	User panel with 3 user buttons, PLC and power supply
	IFD-30.9-50-01 (ETFE, Standard)	100-10158	Standard Firmware	For Standard pump head: K1.48 For High Pressure pump head: K3.48	
2f	IFD-30.9-50-03 (ETFE, High Press.)	100-10178	Housing / Cable	ETFE coated Alu., PP, IP65 ¹ / FEP jacket, open wires, cable length 5 m	
			ATEX / IECEx Marking	CE UK Ex II 3G Ex h mc IIC T4 Gc / CE UK Ex II 3D Ex h tc IIC T90°C Dc	

Table 3: Specification of standard components

Note 1: Designed and tested for IP-67.

Pos.	Article Name	Article #	Shape	Flow Range	Fitting	Cable	Special Feature	Note
3a	LFS-04L-Z-F1-SC1	100-30429	Z	0 – 4 l/min	3/8"	PVC jacket	Calibration for 35-4000	Sensor specific parameter for controller calibration delivered on a tag attached to the flow sensor (for "OEM" model only).
3b	LFS-04L-U-F1-SC1	100-30427	U			0.6 m	ml/min 1% accuracy range.	
4a	LFS-04L-Z-PC-F1-SC1	100-30468	Z	0 – 4 l/min	3/8"	PVC jacket	Calibration for 35-4000	Calibration parameters stored on sensor chip and automatically transferred to driver ("EasyConnect" and "Stand-Alone" models).
4b	LFS-04L-U-PC-F1-SC1	100-30466	U			0.6 m	ml/min 1% accuracy range.	

Table 4: Standard flow sensors

Pos.	Component	Article Name	Article #	Characteristics	Value / Feature
5	Mounting Base Plate	MBP-130.1	190-10313	Material / Mounting Screws	PP + GF / 2 pieces, stainless steel FEP coated, M3 x 10 mm
6a	AC/DC Power Supply	TPC 055-124 (Traco)	100-40014	Voltage Output / Input Basic Dimensions / Certifications	24 VDC with 55 W / 85 – 264 VAC, 47-63 Hz 45 x 90 x 96.5 mm (mountable on DIN rail 35 mm) / UL, CSA, CB, Semi F47
6b	Desktop AC/DC Supply	VEC50US24 HR30	100-40015	Voltage Output / Input / Basic Dim. Cable Spec. / Safety Approvals	24VDC, 50W / 90 – 264 VAC, 47-63 Hz / 116 x 52 x 31 mm, cable length 1.2m IEC60950-1, EN60950-1, UL/cUL60950-1
6c	AC Mains Cables (for Desktop power supply 6b)	AMC-1.1 (2m)	190-10331	Country	US, Canada
		AMC-1.2 / AMC-1.3 (2.5m)	190-10332 / 33	Country	Germany, Denmark, Norway, Finland, Belgium, Netherlands, Sweden, Austria / Japan
		AMC-1.4 / AMC-1.5 (2.5 m)	190-10334 / 35	Country	Switzerland / United Kingdom
7	USB to RS485 Adaptor-TR Isolated	YN-485I-TR	100-30392	Structure/Design Purpose	USB connector (A) with termination resistor and cable (2m) with connector pair (B and C) for external RS485 wire connection. Magnetically isolated. Cable length is 2m. Included is a USB space saver cable (D). Communication over fieldbus of driver with PC.
8	IPS Cable Power 3 Wires	ICP-1.1-50 (5 m)	190-10342	Cable Material / Wires Connection In / Connection Out Main Purpose	PVC jacket / 3x 0.5 mm ² (only 2 wires used, 1 is cut) Open wires / Circular Hirose type to driver Connection of power supply to "Stand-Alone" and "EasyConnect" drivers
9a	IPS Cable Signal 6 Wires	ICS-1.1-01 (0.1 m)	190-10343	Cable Material / Wires	PVC jacket / 6x 0.08 mm ² and shielding
		ICS-1.1-10 (1 m)	190-10344	Connection In / Connection Out	Circular Hirose type / Circular Hirose type
		ICS-1.1-30 (3 m)	190-10345	Main Purpose	Fieldbus cable between "EasyConnect" drivers
9b	IPS Cable Signal 6 Wires	ICS-1.2-50 (5 m)	190-10346	Cable Material / Wires	PVC jacket / 6x 0.08 mm ² and shielding
		ICS-1.3-50 (5 m)	190-10389	Connection In / Connection Out Main Purpose	Connector with screw type plug for open wire connection / Circular Hirose type Fieldbus connection to "EasyConnect" driver / To PLC of "Stand-Alone" driver.
10	IPS Cable Signal 12 Wires	ICS-2.1-50 (5 m)	190-10347	Cable Material / Wires Connection In / Connection Out Main Purpose	PVC jacket / 12x 0.14 mm ² and shielding Connector with screw type plug for open wire connection / Circular Hirose type General connection to PLC of "EasyConnect" drivers.
11	Fieldbus Termination	FTC-1.1	190-10348	Materials Main Purpose	PPS for connector housing and FPM for sealing. Termination of fieldbus.
12a	Chemical Protection Connector Cover	CPC-1.1	190-10349	Main Purpose of CPC-1.1	Chemical protection of driver connectors of ICP-1.x, ICS-1.x and flow sensor cables.
CPC-1.2		190-10350	Main Purpose of CPC-1.2	Chemical protection of driver connectors of ICS-2.x cables.	
CPC-1.5		190-10352	Main Purpose of CPC-1.5	Chemical protection of fieldbus termination connector FTC-1.1	
13a	Impeller Exchange Kit	IEK-30.1 (Standard)	100-90837	Impeller Material / Type (A)	PTFE / (a) LPI-30.1 (b) LPI-30.4
13b		IEK-30.3 (High Pressure)	100-91219	Sealing O-Ring (B) Pump Housing (C) / Motor (D) Screws Exchange Tool IET-30.1 (E)	O-Ring FFPM (FFKM) perfluoroelastomer Dimensions: 28.3 x 1.78 mm Stainless steel PTFE coated, 6 pcs M5 x 14 mm / 4 pcs M3 x 10 mm POM-C
14 A-F	ATEX Cable Sealing System	ACS-A.1 (Roxtec)	100-90292	Sleeve (A) and Gasket (B) Frame (C) and 2x Cable Module (D)	Stainless Steel and EPDM Note: Lubricant (E) and measurement plates (F) are included. Roxylon (EPDM rubber)
15	User Panel	LUI-B.1-01	100-30448	Interface / Housing Rating Standard Firmware	RS485 / IP65 A3.00
16	Water Cooling Module	WCM-130.2 ²	190-10486	Materials Motor Mounting Screws Cooling Flow Pressure Drop / Max. Pressure Purpose	PTFE coated stainless steel for cooling plate (A) and mounting screws (B). 2 x M3x10, stainless steel PTFE coated Min. 0.4 l/min at ≤ 20 °C. In- and outlet are NPT 1/8" x 6.7mm. 10 mbar for 1 l/min cooling flow (for water at 20 °C) / 4 bar Driver cooling for higher liquid temperatures (see user manual).

Table 5: Specification of accessories

Note 1: Designed and tested for IP67. Note 2: Water cooling module is not compatible with ATEX driver IFD-30.9.



Figure 19: Flow control system with standard main components



Figure 20: Standard accessories

Levitronix® is the world-wide leader in magnetically levitated bearingless motor technology. Levitronix® was the first company to introduce bearingless motor technology to the Semiconductor, Medical and Life Science markets. The company is ISO 9001 certified. Production and quality control facilities are located in Switzerland. In addition, Levitronix® is committed to bring other highly innovative products like the LEVIFLOW® flowmeter series to the market.



• LEVITRONIX®
• Representatives

Headquarter and European Contact

Levitronix GmbH
Bändliweg 30
CH-8048 Zurich
Switzerland

Phone: +41 44 974 4000
E-Mail: salesEurope@levitronix.com

US Contact

Levitronix Technologies Inc.
10 Speen Street, Suite 102
Framingham, Massachusetts 01701
USA

Phone: +1 508 861 3800
E-Mail: salesUS@levitronix.com

Japan Contact

Levitronix Japan K.K.
Wing Eight 5floor, 4-16-4
Asakusabashi, Taito-ku
Tokyo, 111-0053 Japan

Phone: +81 3 5823 4193
E-Mail: salesJapan@levitronix.com

Taiwan Contact

Levitronix Taiwan
5F, No. 251, Dong Sec. 1,
Guangming 6th Rd., Chu Pei City,
Hsin-Chu 302, Taiwan, R.O.C.

Phone: +886 3 657 6209
E-Mail: salesAsia@levitronix.com

This document and its content is the property of Levitronix® and shall not be reproduced, distributed, disclosed or used for manufacturing or sale of Levitronix® products without the expressed written consent of Levitronix®.