

**Principle of Operation**

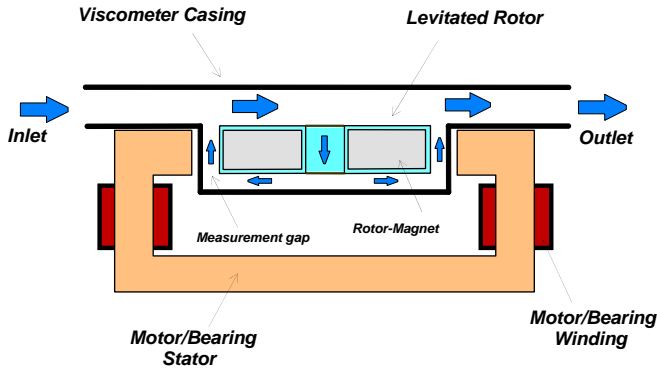

**Figure 1:** Cross-section schematic of the bearingless viscometer (BVM 1.1).

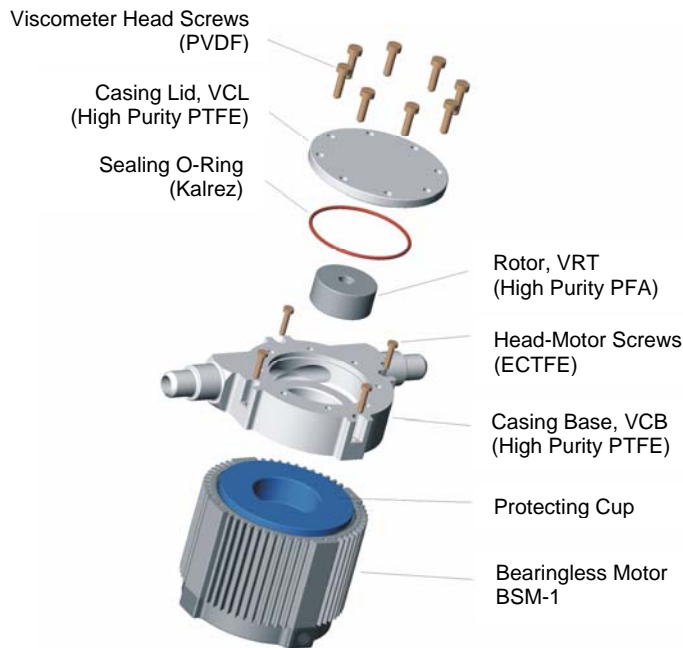

**Figure 2:** Exploded view of bearingless viscometer BVM-1.1.

**REVOLUTIONARY MAGNETICALLY  
LEVITATED ROTATIONAL VISCOMETER**

Levitronix® has developed a unique, rotating, in-line viscometer based on the principle of magnetic levitation.

A rotor is suspended and driven by the magnetic field of a motor/bearing stator through the walls of the viscometer casing without making any mechanical contact (Figure 1). This patented Levitronix® technology provides for a direct measurement of fluid viscosity. The viscometer rotor, which contains a rotor magnet, and the viscometer casing are fabricated from chemical-resistant, high-purity fluorocarbon resins suitable for demanding environments.

The lack of any mechanical bearings enables highly accurate viscosity measurements. A levitated rotor slice is rotating in the process fluid. The motor torque (at given speed) is exclusively determined by the fluid friction losses in the measurement gap and thus proportional to fluid viscosity. Motor torque is derived from the motor drive current in the vector controlled speed controller system.

**SYSTEM BENEFITS**

- Continuous in-line viscosity measurement with fast response time
- All wetted parts are made of PTFE or PFA
- Interface with a variety of display and control capabilities
- Easily mounted in any direction, pipe line, or bypass stream
- Operates in a wide range of pressure and flow values
- No mechanical wear reduces downtime and maintenance costs

**USA:** Levitronix, LLC  
45 First Avenue, Waltham, Massachusetts 02451  
Tel.: +1-781 622 5070, Fax: +1-781 622 5090  
Internet: info@levitronix.com, www.levitronix.com

**Europe:** Levitronix GmbH  
Technoparkstr. 1, CH-8005 Zürich, Switzerland  
Tel.: +41-1-445 19 13, Fax: +41-1-445 19 14  
Internet: info@levitronix.com, www.levitronix.com

## IN-LINE VISCOMETER TYPES and COMPONENTS



Figure 3: Viscometer BVM-1.1 and BVM-1.2 with components

## SYSTEM SCHEMATICS

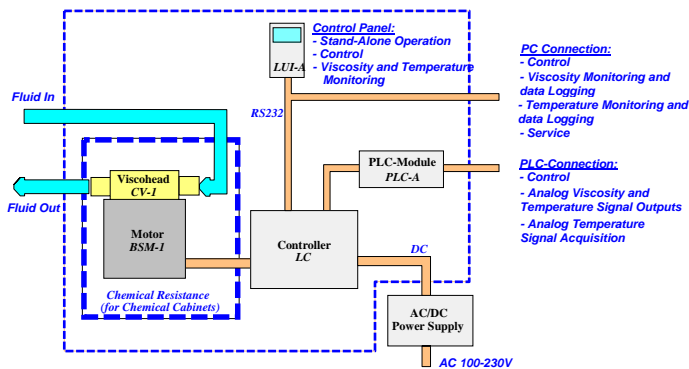

Figure 4: Schematics of bearingless viscometer with components.

## SYSTEM SOFTWARE

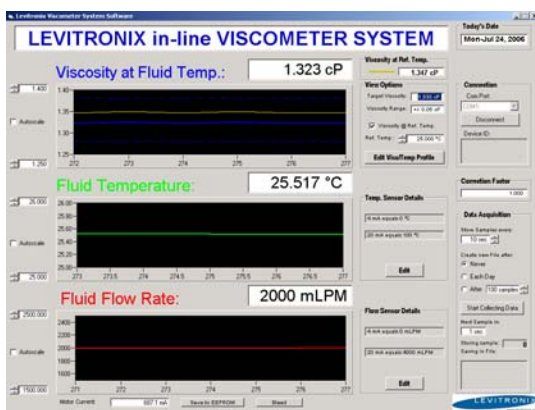

Figure 5: Levitronix Viscometer System Software screen shot

## TECHNICAL SPECIFICATIONS

	BVM 1.1	BVM 1.2
■ Viscosity Range*:	0.5 - 100 mPa.s	100 – 2000 mPa.s
■ Accuracy*:	1 % FS (At specified fluid density)	
■ Repeatability:	0.3 % FS (0.2% of Reading with filtering)	
■ Flow*:	0.5 – 20 Liter/min	10 – 100 mL/min
■ Pressure Drop:	< 0.15 bar	
■ Max. Pressure*:	2.5 bar	1.5 bar
■ Installation:	in any orientation	
■ Temperature Sensor:	PT-100 encapsulated in PTFE body and integrated in sensing element.	
■ Fittings**:	1/2" FlareTek	3/8" FlareTek
■ Wetted Parts:	PTFE, PFA	
■ Input Voltage:	24 VDC	
■ Interface:	PLC, RS232, Control Panel, handheld Simultaneous Viscosity and Temperature analog output.	

\* Contact Levitronix® for special requirements.

\*\* Other connector options, such as NPT, available.

## SYSTEM SOFTWARE CAPABILITIES

- Monitoring viscosity and temperature simultaneously
- One additional analog input channel (Flow rate, pressure)
- Data logging with date and time stamp
- Upper/Lower limits for SPC or alarms
- "Viscosity at Reference Temperature" prediction
- Independent sensor calibration
- Windows-based