

Introduction

The BPS series pump systems can be put in parallel or in series to achieve a redundant pump system. This document shows possible setups, operation modes and describes the replacement procedure of parts in running systems

Parallel Pumping

To get a redundant system pumps can be installed in parallel.

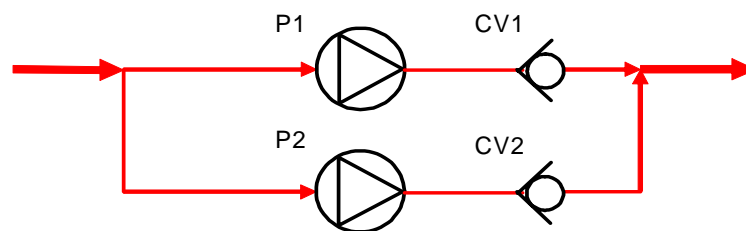

Installation

For a proper function of a parallel setup the installation of check valves in series to each pump is required. Since a centrifugal pump is an open system, a stopped pump allows free flow with hardly no pressure drop. If one pump stops, the check valves avoid the high backflow that would occur due to this small pressure drop. This backflow could easily exceed the flow capacity of the running pump, which causes the loss of output pressure and flow. Instead of a check valve also an automated valve can be used. The valve has to be closed when one pump slows down or stops.

Pump exchange

If one pump has to be replaced, the branch of this pump needs to be isolated (with preinstalled manual valves) and the pump can be exchanged without affecting the running pump. After the exchange, the pump and tubes have to be primed before the manual isolating valves can be opened. For this a bleeding valve can be used.

Operation methods

Running both pumps at the same time

Running both pumps at a time will distribute the total flow among the pumps. At relatively high flow rates and if both pumps are running at the same speed and the plumbing and check valves are the same, the flows are normally well balanced. With the flow also the pump power is balanced, which reduces the pump temperature and thus the reliability of motor and controller. Sharing the flow also provides reserves in situations of unexpected high flow demands. Nevertheless the system should be designed that under normal conditions one pump can deliver enough flow, otherwise the system is not 100% redundant.

Due to the flat pressure-flow characteristic of the Levitronix pumps, the provided pressure of the parallel setup will hardly change if one pump stops. The remaining pump will immediately carry the total flow without the need for significant speed adjustments.

For low flow rates it is not advisable to run both pumps at the same time without an active flow balancing system. The pressure drop in the branches is then so low, that small differences in pump speed or different pressure drop of the components can cause zero flow in one of the pumps. If that happens, the liquid in that pump heats up due to the hydraulic friction losses, which can cause a safety issue or damage the liquid. Levitronix pumps are over temperature protected and will stop when the liquid gets too hot. Since this means also the loss of redundancy, this situation should be avoided.

The efficiency of centrifugal pumps is usually lower at low flow rates. Instead of running two pumps with very low flows, it is more efficient to run one pump at higher flow. The energy consumption and also the liquid temperature will be lower, which could be important, especially in short recirculation loops.

+Good for high flow rates

+Provides reserve for peaks in flow demand

+Very small pressure and flow drop if one pump stops

-Not suited for low flow

-Check valve or automatic valve in series to the pump required

Running one pump at a time (E-call mode)

If only one pump is running at a time, a control system (usually PLC) is needed for the operation. If one pump stops, the control system starts up the other pump.

Depending on the response time of the control system it takes usually 1-5 seconds before the second pump provides full pressure.

To test the availability of both pumps and to avoid aging or damage of the liquid in the standby pump, it is recommended to swap the operating pump from time to time. Swapping from one pump to the other can be done without significant pressure or flow drop. For this both pumps have to run at the same speed before one pump is switched off. If automatic valves are used, it is important that the valves are only operated when both pumps are running at the same speed.

The efficiency of centrifugal pump is usually lower at low flow rates. Instead of running two pumps with very low flows, it is more efficient to run one pump at higher flow. The energy consumption and also the liquid temperature will be lower, which could be important especially in short recirculation loops.

+Good for low and high flow rates

+Less liquid temperature rise

-Pressure and flow drops if pump stops

-Check valve or automatic valve in series to the pump required

Control methods

Running both pumps at the same time

If the total flow is relatively high, both pumps can be operated at the same speed. To run the pump in speed mode and set the speed, please see the user manual or the firmware specification document of your BPS pump system.

If the flow is not equally distributed among the pumps, active flow balancing is necessary (please consider also running just one pump at a time). The pump controller offers the possibility for closed loop control without additional hardware. In the figure below you find a possible setup for balanced flow. With the signal from the flow meter in series to each pump, the controller controls the pump flow. To get balanced flows, the set point flow must be the same for both controllers. It is also possible to use an external PLC for the two control loops and run the BPS systems in speed mode.

In this case the total flow is the sum of both pump flows. It is also possible to measure the total flow and just one pump flow and change the set point flows for

each pump accordingly.
 In case of a pump failure, the set point of the pump flow has to be changed to the total flow that is required.

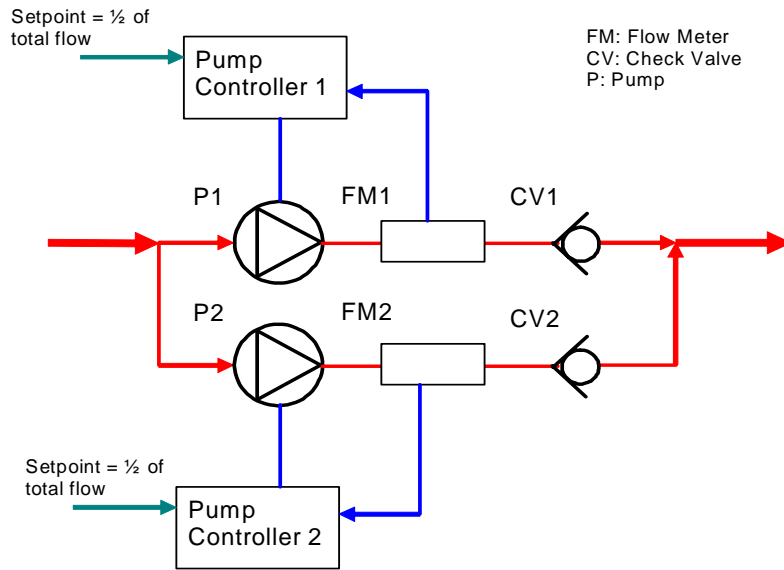

Figure 1: flow balancing and control

For closed loop pressure control a second pressure control loop can be added (see Figure 2). If the flow rate is relatively high, active balancing is not required. In case of a pump failure, the pressure controller automatically changes the set point flow of the remaining pump.

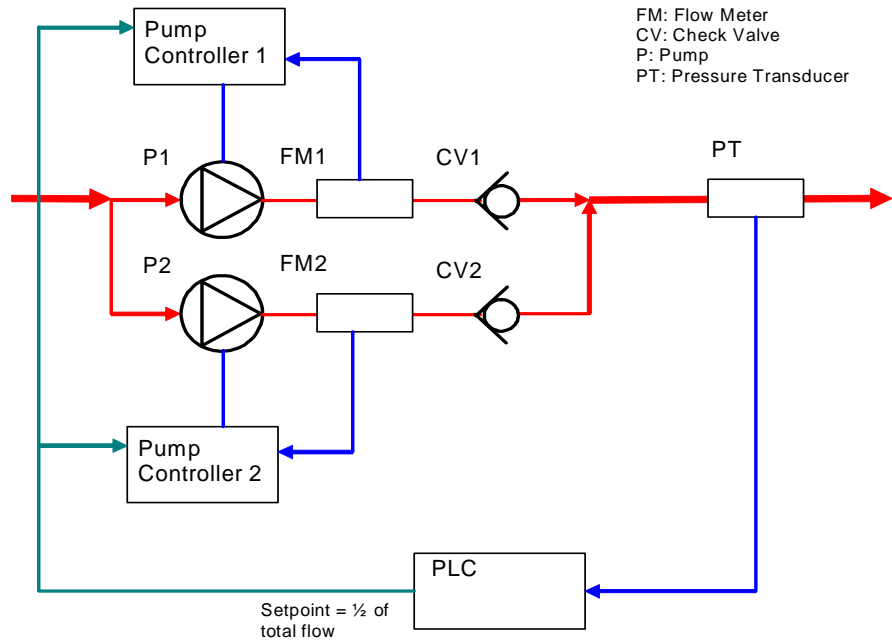
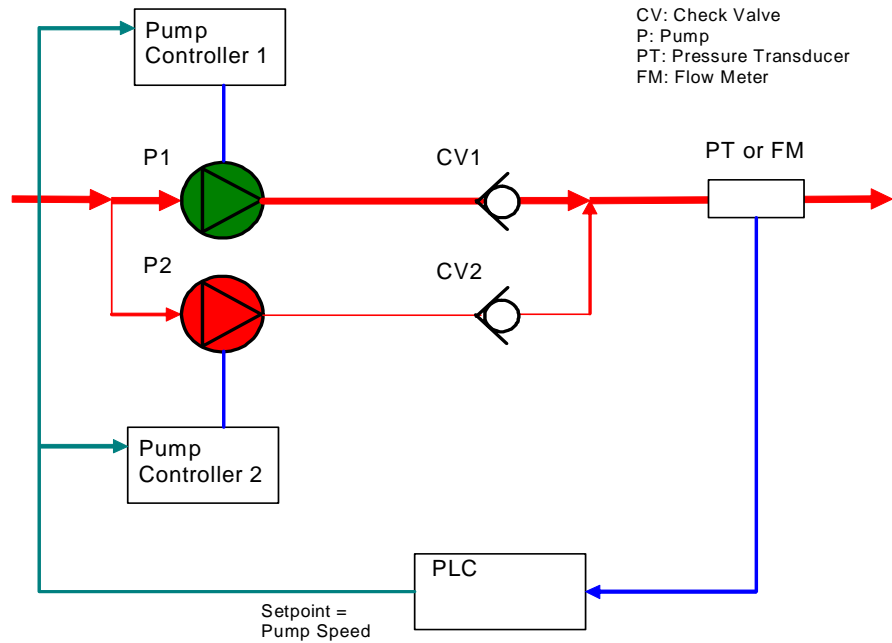

Figure 2: Pressure control with balanced flow

Running just one pump at a time

When only one pump is running at a time, a PLC is needed to manage the pump operation. If closed loop control is required, either the pump controller or the PLC can be used. During the transition from one pump to the other, the set point speed for both pumps should be the same. This guarantees minimum pressure or flow drop and prevents pump backflow if no check valve is used.



Pumps in Series

To get a redundant system pumps can be installed in series.

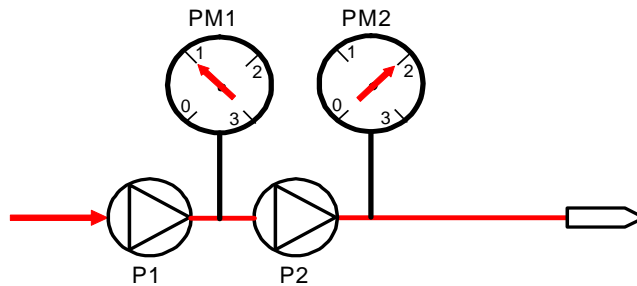

The BPS pump system is an open system that can be compared to a small piece of tube when the pump is not running. The pressure drop over a not running pump is very low, even at high flow rates. The total pressure of the series setup is the sum of both differential pump pressures. Since there is no danger of a back flow or hydraulic short circuit, no check valves are needed.

Pump exchange

If one pump has to be removed from the system, a bypass is needed. Before the bypass can be used, it has to be properly primed. Otherwise the air of the bypass can cause the loss of prime of the remaining pump, which causes an immediate loss of pressure and flow rate. The bypass can also be permanently primed if the liquid allows that. A constant low flow rate in the bypass is recommended for Slurry applications, when the liquid should be moved all the time.

Operation methods

Running both pumps at the same time

Running both pumps at the same time is the recommended way of running the system. The speed of each pump is then lower than with only one running pump, which distributes the total pump power between the two pumps. Usually also the total efficiency is higher and thus the energy consumption and the temperature rise of the liquid is lower.

If one pump stops, the pressure (and also the flow rate) drops by approximately 50% until the remaining pump speeds up to compensates the loss.

- +Good for high and low flow
- +Provides reserve for peaks in pressure demand
- +No check valve or automatic valve in series to the pump
- Bypass needed for replacement
- Short term pressure drop if one pump stops

Control methods

Running both pumps at the same time

Both pumps should run at the same speed.

To control the system the use of a PLC is recommended. A closed flow or pressure control loop can be built up with the PLC. If both pumps get the same set point speed, the closed loop pressure or flow control automatically ramps up the speed of the remaining pump. No further control algorithms are needed.

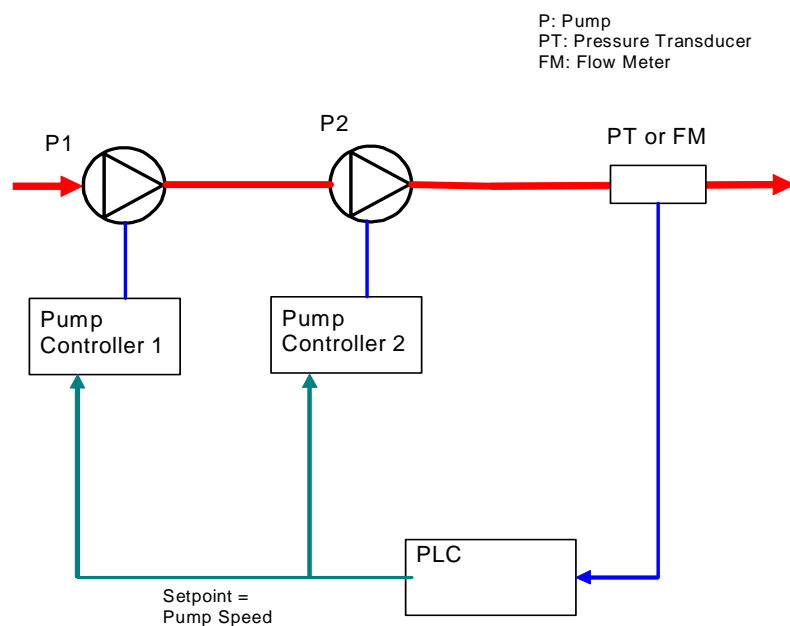

Figure 3: Closed loop pressure or flow control

Electrical Interface

Operation Modes

Depending on the firmware of the BPS pump system, the interface of the pump is different. The standard interface can be used for either “**speed mode**” or “**process mode**”.

Speed Mode:

The pump controller runs the pumps at constant speed independent from the load (flow rate). The speed set point can be set with an analog signal or via RS232.

Process Mode:

A sensor signal from a pressure transducer or flow meter is used to control the measured value. The sensor signal is fed directly to an analog input of the controller and the programmable PID-controller adjusts the pump speed. The control parameters can be set with the Windows based Levitronix Service Software.

Standard Firmware

The figure below shows the state diagram of the PLC-state machine. The state transitions are released by changes of the digital controller inputs. The speed or control set point is given by the analog input signal. Please refer also to the user manual and the according firmware specification document.

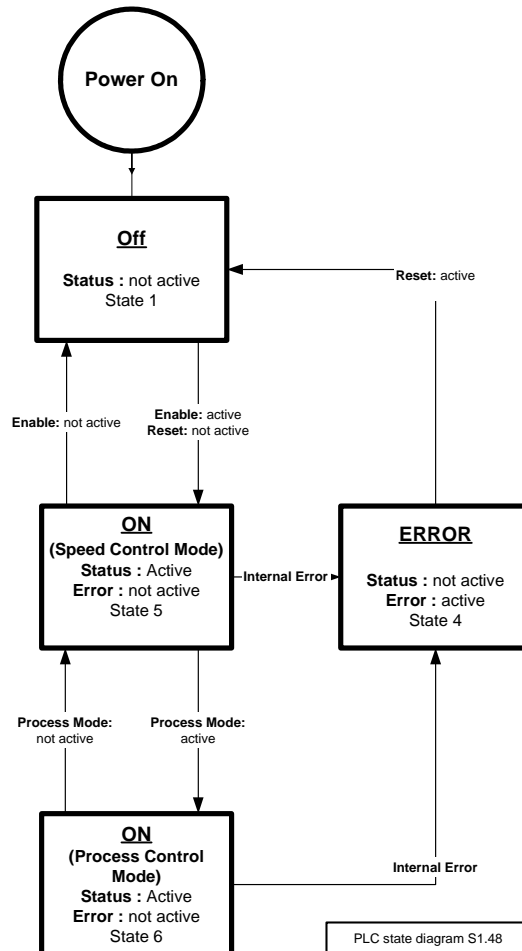

Figure 4: PLC state diagram of "Standard Firmware"

PLC Failsafe Firmware

In case of a PLC failure or shut down, the BPS would stop if the standard firmware was installed. In some applications it would make sense that the pumps keep running at the same speed. The following figure shows the state diagram that provides such functionality. Commands for the pump controller need a “clock” pulse on one of the digital inputs. If the PLC does not send any signals, the pump stays at the last point of operation that was set. For manual operation of the pump, the RS232 interface can be still used. This can be done with the Levitronix handheld user interface or with the Windows based Levitronix Service Software.

<i>D In 1</i>	<i>D In 2</i>	<i>D In 3</i>	<i>Action</i>
Low	Low	Rising slope (*)	OFF
Low	High	Rising slope (*)	ON speed mode
High	Low	Rising slope (*)	ON process mode
High	High	Rising slope (*)	Read set point value

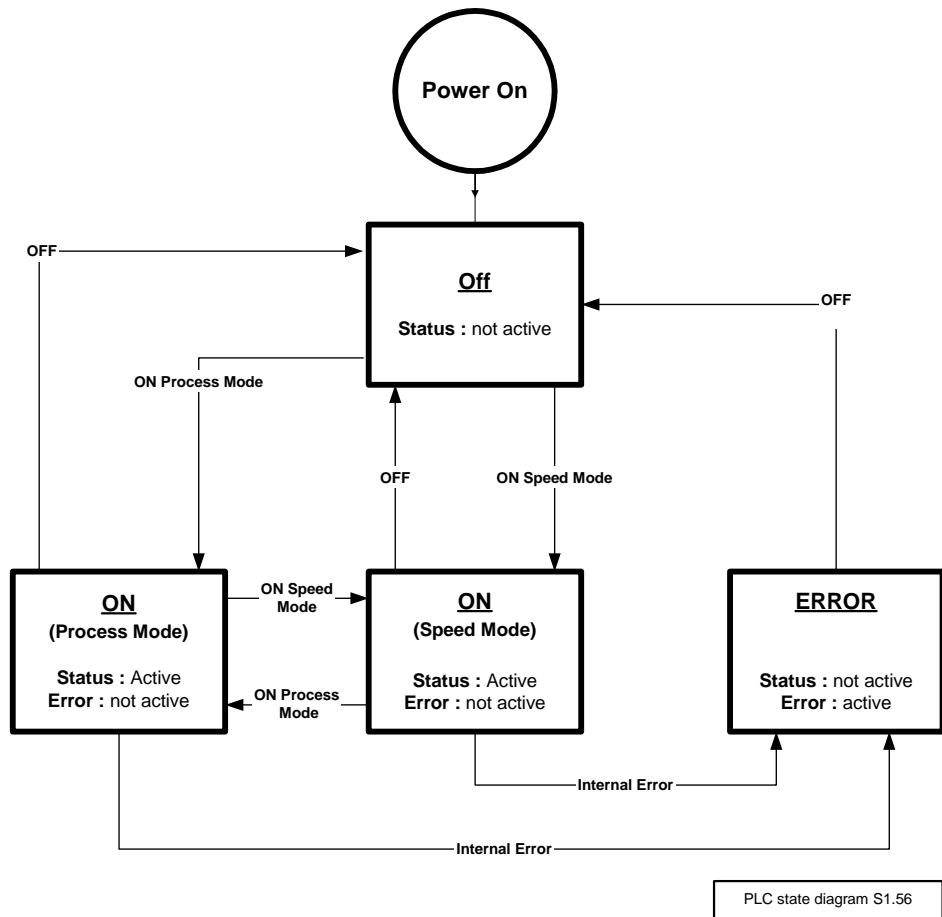

Figure 5: PLC state diagram of "PLC Failsafe Firmware"

Operating the system via RS232 is also possible. Since there is no watchdog implemented for the RS232 communication it is also possible to use it for PLC failsafe operation.