

Introduction

Levitronix® provides a closed-loop flow control system for point-of-use slurry flow control. The system mainly consists of a *Bearingless Pump System 1 (BPS-1)* and a flowmeter. The flow controller itself is implemented on the pump controller of the *Bearingless Pump System*.

Closed-loop flow control systems are provided for an overall flow range of

- 60 – 1200 mL/min.

Please contact *Levitronix*® for special requirements.

Levitronix® has designed the closed-loop flow control system to offer the following benefits:

- Closed-loop flow control system
- Precise liquid flow control
 - Precise pump speed control capability
 - Flow accuracy defined by external flowmeter (2% with Malema M-1500)
- High control dynamics
 - High pump dynamics
 - Closed loop flow control dynamic dependant on flowmeter (about 1 sec with Malema M-1500)
- Alarming capability for flow, speed, current, temperature, line clogging
- Dynamic Condition Trending (DCT) capability (enables failure prediction and scheduling of preventive maintenance)
- Continuous smooth process flow (no pulsation)
- Independent from pressure on slurry delivery line (no minimum pressure required!)
- Slurry saving based on reduced slurry flow rate
- Low cost of ownership and reduced maintenance costs
 - No pump tubing exchange
- Higher Yield
 - No polymer particles
 - Better process control

System Overview

All wetted parts of the hydraulic components are made out of fluorocarbon resins. The sensor signal of the flowmeter is fed to the pump controller of the *BPS-1* system. The closed loop flow controller is running on the pump controller itself. The pump speed is set, so that the actual flow (signal coming from the flowmeter) corresponds to the reference signal (signal coming from the tool). To handle pre-pressure and pressure fluctuations on the inlet side of the pump a pressure regulator is needed, which has to be installed before the pump. The pressure regulator is necessary, whenever slurry is coming from a delivery loop. The system overview is shown in *Figure 1*.

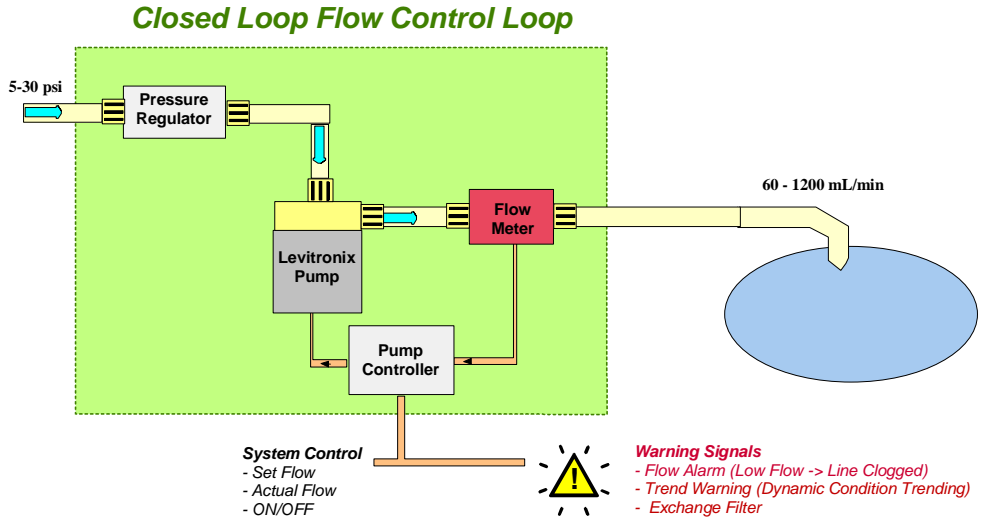

Figure 1: System Overview of the Closed-Loop Flow Control System

Priming Solution for Stand-Alone Operation

If slurry is coming from a drum standing beside the tool, a priming solution must be installed instead of the pressure regulator. Whenever priming of the *Bearingless Pump System* cannot be accomplished by gravity feeding to the system, vacuum can be used to prime the pump.

A priming solution, consisting of a 3-way valve and a venturi valve, is described in the *Figure 2* (for other priming solutions please refer to the Technical Note *Priming of BPS-Series Bearingless Pump Systems*). During the priming process the 3-way valve links the suction line and the *Levitronix* pump to the venturi (aspirator). When the suction line and pump are filled with liquid, the venturi can be separated by switching the 3-way valve directing the flow to the process. To avoid loss of prime, the *Levitronix* pump should be running before the 3-way valve switches to the process line. To prevent the formation of airlocks in the pump, the pump should run at low speed (1000 - 2000 rpm) during the priming process. An even more effective method is to pulsate from 0 rpm to speed values between 1000 rpm and 2000 rpm.

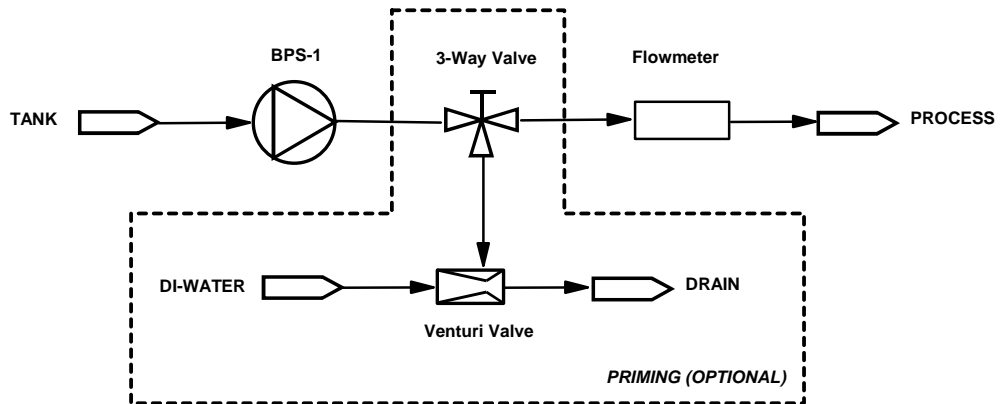

Figure 2: Priming Solution for Stand-Alone Operation

Dynamic Condition Trending (DCT)

The system provides an actual flow signal and a *Flow Alarm*, whenever actual and reference flow don't correspond. So low flow conditions are detected, for example caused by line clogging. In addition a *Trend Warning* is provided, which enables failure prediction and scheduling of preventive maintenance. This so-called *Dynamic Condition Trending (DCT)* feature is based on pump speed information. *Figure 3* basically describes the function of this feature.

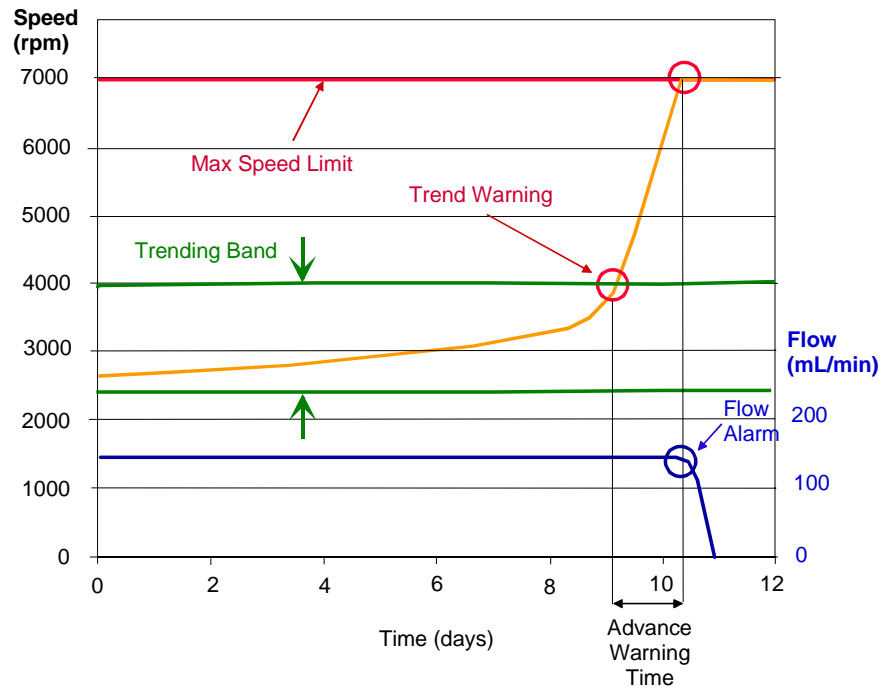

Figure 3: Dynamic Condition Trending (DCT) of Levitronix Flow Control System

The *Trend Warning* is some kind of advance warning. A warning on potential line-clogging is generated. The *Trend Warning* information is given by the pump speed.

Example: The flow control system is usually running with a pump speed of 2600 rpm for providing 150 mL/min (maximum pump speed is 7000 rpm). If any component starts clogging (e.g. filter) the pressure drop in the loop is increasing, which means pump speed is slowly ramping up to provide the set flow of 150 mL/min. So if pump speed exceeds 4000 rpm, the system provides a *Trend Warning*. The system is still able to provide the desired flow rate (there are still 3000 rpm until maximum speed is reached) but there might be an issue in the future. That gives time to schedule a preventive maintenance action. (All above mentioned parameters are configurable).

System Operation

The *Levitronix*[®] flow control system can be operated by a single analog signal (via the PLC- Interface module). The following table gives an overview which signal must be provided from the customer to operate the system and which signals are provided from the *Levitronix*[®] system. That simple controller interface enables fast and easy integration to the tool software. Contact *Levitronix*[®] for special requirements.

Signals which must be provided by the customer	Signal Type	Levels	Description
Reference Value (incl. Control System Startup)	Analog Signal (0 – 10 V)	0..10V = 0..100% (of flow range) >0.6V control system on <0.4V control system off	The flow is controlled regarding to the reference flow value. The control system is turned on, whenever the signal is above 0.6V and turned off, whenever it is below 0.4V (both values configurable).

Table 1: PLC-Signals which must be provided from the Customer

Signals which are provided from the Levitronix System	Signal Type	Levels	Description
Actual Flow	Analog Signal (0 – 5 V)	0..5 V = 0..100% (of flow range)	Actual flow value.
Status	Digital Signal (Relais open / closed)	Relais closed ⇒ active, control system on Relais open ⇒ not active, control system off	Status of the control system.
Trend Warning (DCT)	Digital Signal (Relais open / closed)	Relais closed ⇒ not active Relais open ⇒ active	Whenever the pump speed exceeds a specified limit, the <i>Trend-Warning</i> flag is active. This means that there is a potential problem in the process line in the future (for example beginning of any line or filter clogging).
Flow Alarm or System Error	Digital Signal (Relais open / closed)	Relais closed ⇒ not active, system ok Relais open ⇒ active, system not ok	Whenever the <i>Flow Alarm</i> flag is active, significant stationary deviation between reference and actual value is pending. Check, if the process line is clogged. This flag is active as well, when a system error occurred and the system shut down.

Table 2: PLC-Signals which are provided from the Levitronix System

Technical Support

For troubleshooting, support and detailed technical information contact *Levitronix*[®] *Technical Service Department*.

Levitronix Technical Service Department
Technoparkstrasse 1
8005 Zurich
Switzerland
Phone: +41-1-445 13 31
E-Mail: support@levitronix.com